

















# Description of the functions, IQlogic

## Contents

<b>General</b>		
Control .....	168	
Reading .....	168	
IQnavigator Hand-held Terminal and Image Management .....	169	
Dashboard .....	169	
Log diagram .....	170	
Flow chart .....	170	
Information pages, integrated description of functions .....	171	
Main setup .....	171	
<b>Air flow</b>		
Regulation mode .....	172	
Optimize .....	172	
Set point displacement .....	172	
Air adjustment .....	172	
Outdoor air compensation .....	173	
Booster diffusers .....	173	
Automatic functions .....	173	
<b>Temperature</b>		
ERS Regulation (control) .....	174	
Supply air regulation .....	175	
Extract air/Room regulation .....	175	
Seasonal controlled temperature regulation .....	175	
ORE regulation .....	176	
ORS regulation .....	176	
Night compensation .....	177	
Set point displacement .....	177	
Neutral zone .....	177	
Dew point compensated supply air .....	177	
External temperature sensors .....	177	
Regulation sequence .....	178	
Min. exhaust air .....	178	
Heating boost .....	179	
Cooling Boost .....	179	
Intermittent night heat .....	180	
Morning Boost .....	180	
Summer night cooling .....	180	
Down regulation (airflow/pressure) .....	180	
<b>Time and schedule</b>		
Time and schedule .....	181	
<b>Energy monitoring</b>		
Energy monitoring .....	182	
<b>Filters</b>		
Filters .....	183	
<b>Software</b>		
Software .....	183	
<b>Language</b>		
Language .....	183	
<b>Alarm management</b>		
Alarm management .....	184	
<b>Log</b>		
Log .....	186	
<b>Air handling unit</b>		
Settings .....	186	
Fan status .....	186	
Operation time .....	186	
VOC/CO <sub>2</sub> sensor .....	186	
Automatic functions .....	186	
<b>Heating</b>		
Preheating the air .....	187	
Extra regulation sequences 1 and 2 .....	187	
Combi coils .....	187	
Re-heating .....	188	
Season Heat .....	188	
Xzone temperature regulation .....	189	
<b>Cool</b>		
Extra regulation sequences 1 and 2 .....	190	
Cool .....	190	
Xzone temperature regulation .....	191	
COOL DX .....	191	
Delay time .....	191	
Outdoor air limits .....	191	
Air flow, limits .....	191	
<b>Heat exchangers</b>		
Control .....	192	
Carry over control .....	192	
AQC, Air Quality Control .....	192	
Efficiency measurement .....	192	
Defrost (rot. heat exch.) .....	192	
Automatic functions .....	193	
<b>HC</b>		
HC .....	194	
<b>SMART Link</b>		
SMART Link .....	195	
SMART Link+ .....	196	
<b>Relative humidity</b>		
Humidifying .....	197	
Dehumidification .....	197	
Hygrostatic rotor controller .....	197	
<b>ReCO<sub>2</sub></b>		
ReCO <sub>2</sub> .....	198	
<b>All Year Comfort (AYC)</b>		
All Year Comfort .....	199	
<b>MIRU</b>		
MIRUVENT – GOLD .....	200	
<b>Inputs / Outputs</b>		
Inputs / Outputs .....	202	
<b>Communication</b>		
Communication .....	203	
<b>Base setting</b>		
Base setting .....	204	
<b>Manual test</b>		
Manual test .....	205	
<b>IQnavigator</b>		
IQnavigator (hand-held terminal) .....	205	
<b>File manager</b>		
File manager .....	205	

# Description of the functions

## General

---

### Control

The hand-held terminal controls the GOLD to the various operating modes.

The air handling unit normally operates in the automatic operation mode and is then controlled via the internal switch clock.

It is also possible to remote control the air handling unit to operate in the low speed or high speed mode beyond the ordinary operating times.

Via the hand-held terminal, you can manually stop the air handling unit or control it to operate in the low speed or high speed mode.

External disconnection stops the air handling unit, making it possible to stop the unit from a remote location.

Control and power supply (24 V) for dampers are provided via terminal blocks on the GOLD unit's control unit. Dampers open on starting the air handling unit and close on shutting down the air handling unit.

### Status

Actual operating readings and settings such as flows, temperatures, the output values of the regulation sequences, status of the inputs and outputs, filter pressures, SFP values, energy monitoring as well as alarm history, etc., can be viewed under the relevant function in the hand-held terminal.

# Description of the functions

## General

### IQnavigator Hand-held Terminal and Image Management

The IQnavigator hand-held terminal features a 7" multi-touch screen and is very simple and easy-to-use. Commissioning and the entering of settings are managed intuitively and in steps. Flow diagrams and help texts for functions and alarms are always at hand.

The hand-held terminal is equipped with a three metre long connection cable that can be connected via quick-fit connector to the air handling unit's control unit.

The air handling unit's control unit is as standard equipped with a WLAN antenna. This makes it possible to simply connect a computer, tablet computer or mobile telephone via Wi-Fi, and get the same image management as that in the hand-held terminal.

The preset values are stored and will not be unaffected in the event of a power failure.



### Dashboard

The dashboard is normally shown in the handheld terminal if no other image has been selected.

#### Flow chart

The flow chart shows the basic air handling unit with the possibility to read the set point values/actual values for temperatures, air pressure, flow and output signals. The flow chart can be configured in terms of the type of heat exchanger, right/left design and fan position to ensure the correct display of values.

#### Current operation status

Current operation status can be read. Other specific operating statuses that affect the ordinary operation status are also shown here, for example, summer night cooling, start-up sequence, post-cooling of electric air heaters, cooling recovery, intermittent night operation, etc.

#### Changing the operating mode

You can start and stop the air handling unit or change over to manual or automatic operation from the dashboard.

#### Alarm log

Active alarms, pending alarms and alarm history (50 latest) can be viewed under Alarm log.



# Description of the Functions

## General

### Log diagram

A number of parameters can be read in diagram form. Up to four signals can be freely selected and read on the hand-held terminal and up to six signals can be freely selected and read via the embedded web page. The log diagram's time interval can be selected as follows: 4 hours, day, week, month or year.

It is possible, via a cursor, to read values for selected signals for a specific date and a specific time.

It is also possible to choose to mark one of the signals to display it with a thicker line in the log diagram.

The program automatically adjusts the resolution of the signals. This means that the program adapts the amplitude of the signal to the height of the diagram within the selected time interval.

The Log diagram can be selected in two types: History or Real time.

The GOLD air handling unit's control unit is as standard equipped with an SD card that long-term stores all the parameters.

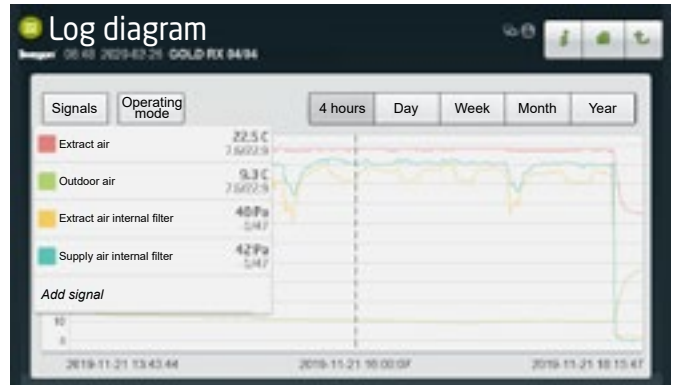

### Flow chart

A complete flow chart with all included accessories can be shown by pressing on the dashboard's ordinary flow chart. Current actual values, output signals and set point values are also shown for these.

The flow chart is editable.

The positions of all the components are interchangeable, for example the mutual order between the air heater and the air cooler.

Components that are not automatically generated and be selected.

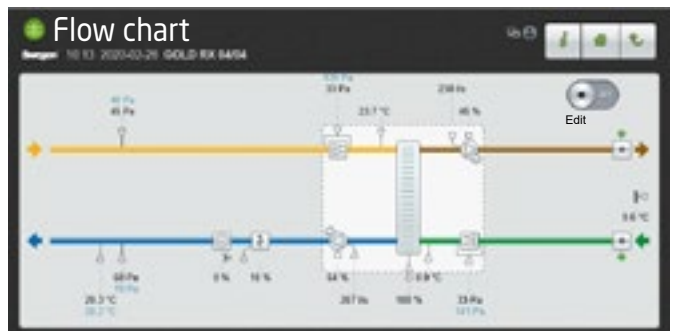

# Description of the Functions

## General

### Information pages integrated description of functions

There is an information page on each menu on the hand-held terminal and web page.

Pressing the information button opens a new window with a description of the function that is currently shown in the menu.

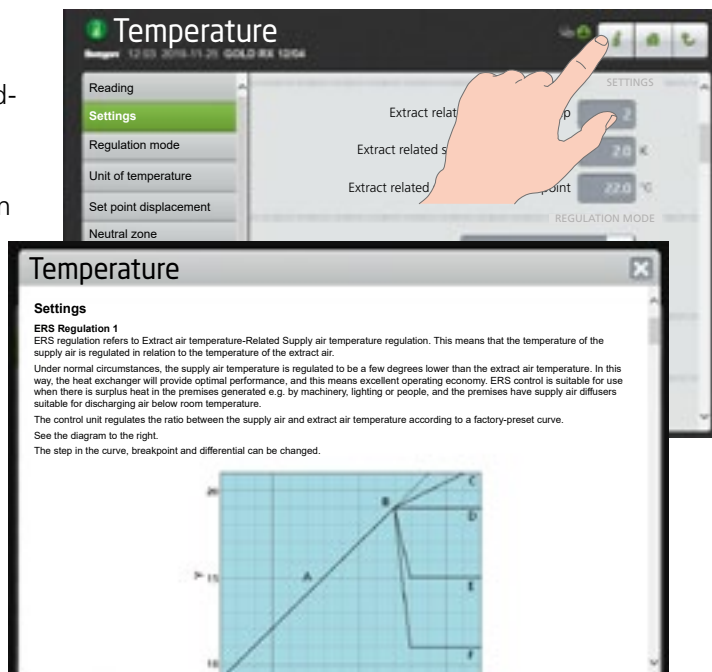

### Main setup

Main setup can be selected when installing the AHU and is an aid for configuring and starting up the AHU.

Time and date, airflow unit, airflow regulation mode, airflow operation level, temperature regulation, temperature settings and fan position settings can be entered here.

## Description of the functions

### Air flow



#### Regulation mode

The regulation mode can be selected individually for the supply air or the extract air respectively.

#### Air flow

Flow regulation involves operating the air handling unit to keep the preset airflow constant. The speed of the fans is automatically regulated to provide correct airflow even if the filters begin to become clogged, if air diffusers become blocked, etc.

Set point (separate for low speed and high speed) is set on the required air flow unit (l/s, m<sup>3</sup>/s, m<sup>3</sup>/h or cfm).

A constant airflow is advantageous, since the airflow is always at the level preset from the beginning.

#### Duct pressure

The airflow automatically varies to provide constant pressure in the ducting. This regulation mode is therefore also called VAV Regulation (Variable Air Volume).

Pressure regulation is used when e.g. damper operations increase the air volume in sections of the ventilation system.

The duct pressure is measured by an external duct pressure sensor (accessory). Set point (separate for low speed and high speed) is set on the required pressure unit (Pa, psi or in.wc).

The function can be limited so that the fan speed will not exceed the preset max. values.

#### Demand

The flow demand is regulated via an external sensor, such as a carbon dioxide sensor that is wired to control unit. Set the desired setpoint, separate for operation in the low speed mode and high speed mode, as a percentage of the input signal or in ppm.

The function can be limited so that the flow will not be higher or lower than the preset max. and min. permissible values respectively.

#### Slave

The flow is constantly regulated to the same value as the other fan. If one fan is pressure-controlled or demand-controlled, the other one can be controlled as a slave to generate the same airflow.

The performance of the slave fan can be restricted if its maximum flow is set to a lower airflow rate.

It is also possible to set a flow difference between the slave controlled fan and the other fan. The setting occurs in a fixed flow difference and/or a percentage difference. For example, this can be used when there is a separate extract air fan and balanced ventilation is wanted.

It is not possible to control both fans as slaves. If you select one fan to operate as a slave, you lose the option to select the other fan as a slave.

#### Optimize

The Optimize function is used when GOLD is connected to a WISE system.

When the function is enabled, SuperWISE gives the set point pressure value to GOLD to optimize the pressure in the duct system, which gives optimal energy efficiency.

The function requires the control type to be set to duct pressure.

#### Set point displacement

Set point displacement can be used e.g. in assembly halls, where a higher rate of air change is needed under full-load conditions.

The airflow is regulated between two flows from an external signals, e.g. from a potentiometer.

The IQlogic<sup>+</sup> module accessory is required.

The function is activated only when the AHU fans operate at high speed.

#### Air adjustment

The speed of the fans can be locked for up to 72 hours. When the function is activated, the speed is locked at the current speed of operation. This is practical when making airflow adjustments in the duct system and air terminals.

## Description of the functions

### Air flow



#### Outdoor air compensation

Outdoor air compensation of the airflow can be activated if you want to change the airflow for specific outdoor air temperatures. An individually adjusted curve regulates the ratio between the airflow and the outdoor air temperature. The curve has four adjustable breakpoints..

If the function is selected solely for low speed or high speed operation, the curve will regulate only one of these. The airflow for the operating case that has not been selected will then be according to the preset set point for airflow/duct pressure.

In the flow regulation mode, the current set point for airflow is changed. When pressure regulation is selected, the current set point for pressure is changed. The function has no effect if the airflow is demand-controlled.

#### Booster diffusers

The Booster diffuser function is used together with the conical diffuser FALCON C or the low speed diffuser BOC or the equivalent.

The diffuser is equipped with a motorized damper that controls the distribution pattern in the diffuser. The damper switches position depending on whether the supply air is warmer or cooler than the room air/extract air.

An indicator is displayed if heating or cooling is active.

The IQlogic+ module accessory is required.

#### Automatic functions

##### Density-corrected airflow

The density of the air is different at different temperatures. This means that a specific volume of air changes at various air densities. The AHU automatically corrects this, so that correct air volume is always obtained.

The control equipment always displays the corrected airflow.

##### Pressure balance corrected extract airflow, rotary heat exchanger

The extract airflow is corrected by continuously measuring the pressure balance across the rotary heat exchanger. The extract airflow is guaranteed with consideration given to the air purging and leakage air flow.

The current air purging and leakage air flow can be read.

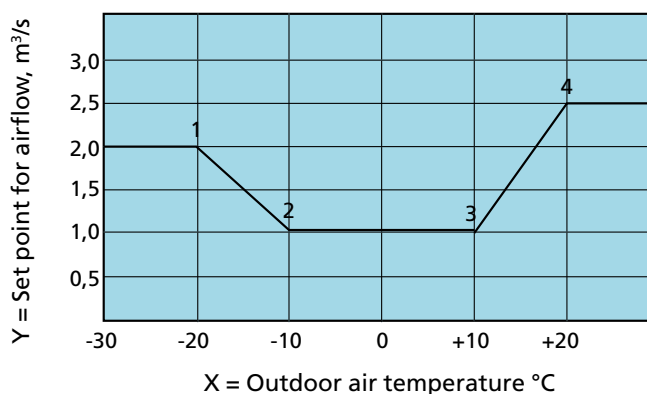

Example:

Flow regulated air handling unit The same principle can be applied to a pressure regulated AHU, however this will cause a reduction in pressure in Pa.

If the outdoor air temperature is under -20 °C (X1), the flow set point will be a constant 2.0 m³/s (Y1).

If the outdoor air temperature is between -20 °C (X1) and -10 °C (X2), the airflow will decrease from 2.0 m³/s (Y1) to 1.0 m³/s (Y2) as shown in the curve.

If the outdoor air temperature is between -10 °C (X2) and 10 °C (X3), the flow set point will be a constant 1.0 m³/s (Y2 and Y3).

If the outdoor air temperature is between 10 °C (X3) and 20 °C (X4), the airflow will increase from 1.0 m³/s (Y3) to 2.5 m³/s (Y4) as shown in the curve.

If the outdoor air temperature is over 20 °C (X4), the flow set point will be a constant 2.5 m³/s.

# Description of the functions

## Temperature



### General

If only GOLD SD supply air handling units are installed, they require an external room sensor for ERS, ORE and extract air regulation.

### ERS Regulation (control)

ERS regulation refers to Extract air temperature-Related Supply air temperature regulation. This means that the temperature of the supply air is regulated in relation to the temperature of the extract air.

Under normal circumstances, the supply air temperature is regulated to be a few degrees lower than the extract air temperature. In this way, the heat exchanger will provide optimal performance, and this means excellent operating economy. ERS control is suitable for use when there is surplus heat in the premises generated e.g. by machinery, lighting or people, and the premises have supply air diffusers suitable for discharging air below room temperature.

### ERS Regulation 1

The control unit regulates the ratio between the supply air and extract air temperature according to a factory-preset curve.

See the diagram to the right.

The step in the curve, breakpoint and differential can be changed.

### ERS Regulation 2

Used if the factory preset performance curve in the ERS Control 1 function does not provide the results desired to meet special needs and conditions. Depending on which setting have been entered, the installation of an air heater for reheating may be required.

An individually adjusted curve regulates the ratio between the supply air and the extract air temperature. The curve has four adjustable breakpoints.

See the diagram to the right.

### ERS Regulation 1

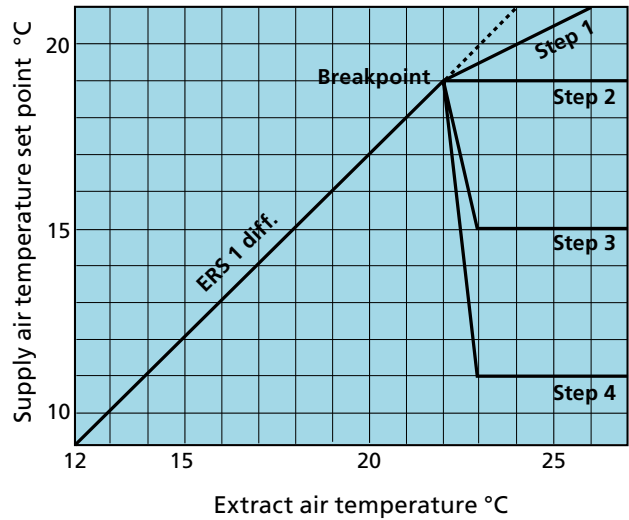

Factory setting means:

If the extract air temperature is below 22 °C (breakpoint), the supply air temperature set point will be automatically regulated to be 3 K (diff.) lower.

If the extract air temperature is above 22 °C, the supply air temperature set point will constantly be 19 °C (step 2).

### ERS Regulation 2

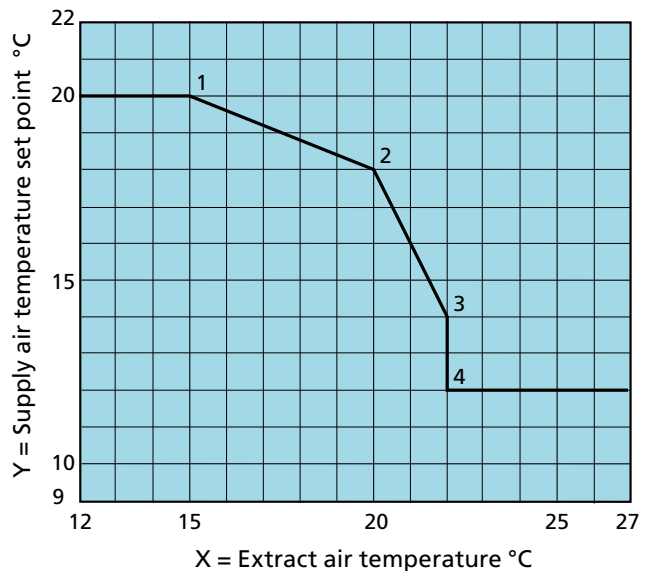

Breakpoints according to factory setting involve the following:

If the extract air temperature is below 15°C (X1), the supply air temperature set point will constantly be 20 °C (Y1).

If the extract air temperature is between 15 °C (X1) and 20 °C (X2), the supply air temperature set point is regulated from 20 °C (Y1) down to 18 °C (Y2) as shown in the curve.

If the extract air temperature is between 20 °C (X2) and 22 °C (X3), the supply air temperature set point is regulated from 18 °C (Y2) down to 14 °C (Y3) as shown in the curve.

When the extract air temperature is 22 °C (X4), the supply air temperature set point is regulated from 14 °C (Y3) down to 12 °C (Y4).

If the extract air temperature is over 22 °C (X4), the supply air temperature set point will constantly be 12 °C (Y4).



## Description of the functions

### Temperature



#### Supply air regulation

Supply air regulation involves maintaining a constant supply air temperature without consideration to the load in the premises.

Supply air regulation can be used when the load and temperatures of the premises are predictable or when the air temperature is post treated on a room level. In most cases this requires the installation of an air heater for reheating, possibly an air cooler as well.

Set point for the supply air is set on the required unit (°C or °F).

#### Extract air/Room regulation

Extract air/ room regulation involves maintaining a constant temperature in the extract air duct (the premises), by regulating the supply air temperature.

The result will be a uniform temperature in the premises regardless of the load. Extract air regulation requires the installation of an air heater for reheating, possibly an air cooler as well.

Set point for the extract air is set on the required unit (°C or °F). The lowest and the highest permitted supply air temperatures are specified.

The extract air temperature is measured by the temperature sensor inside the GOLD unit. If this internal temperature sensor does not give sufficiently representative extract air temperature readings, one or more external room temperature sensors can be installed and connected to the control unit.

#### Seasonal controlled temperature regulation

Seasonal controlled temperature regulation makes it possible to have two temperature regulation modes that alternate at preset outdoor temperatures.

If the ordinary temperature and seasonal controlled temperature regulation are to be of different types, these can be combined freely, for example, ordinary temperature regulation = ERS 1 and seasonal controlled temperature regulation = supply air.

In instances where the same type of ordinary temperature regulation and seasonal controlled temperature regulation are desired, this can be selected for supply air control and extract air control. Values for seasonal controlled temperature regulation can then be set independently of values for ordinary temperature regulation.

# Description of the functions

## Temperature



### ORS regulation

ORE regulation refers to Outdoor air temperature-Related Supply air temperature regulation. This means that the temperature of the supply air is regulated in relation to the temperature of the outdoor air.

An individually adjusted curve regulates the ratio between the supply air and the outdoor air temperature. The curve has four adjustable breakpoints.

### ORS regulation

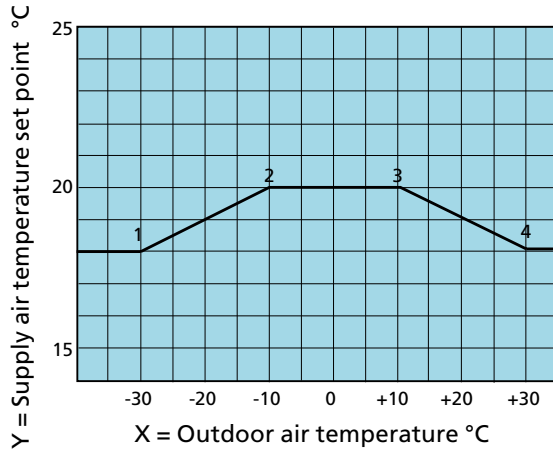

Example:

- If the outdoor air temperature is under -30 °C (X1), the supply air temperature set point will constantly be 18 °C (Y1).
- If the outdoor air temperature is between -30 °C (X1) and -10 °C (X2), the supply air temperature set point is regulated from 18 °C (Y1) up to 20 °C (Y2) as shown in the curve.
- If the outdoor temperature is between -10 °C (X2) and +10 °C (X3) the supply air set point will constantly be 20 °C (Y3).
- If the outdoor air temperature is between +10 °C (X3) and +30 °C (X4), the supply air temperature set point is regulated from 20 °C (Y3) down to 18 °C (Y4) as shown in the curve.
- If the outdoor air temperature is over 30 °C (X4), the supply air temperature set point will constantly be 18 °C (Y4).

### ORE regulation

ORE regulation refers to Outdoor air temperature-Related Extract air temperature regulation. This means that the extract air temperature is regulated in relation to the outdoor air temperature.

An individually adjusted curve regulates the ratio between the extract air and the outdoor air temperature. The curve has four adjustable breakpoints.

### ORE regulation

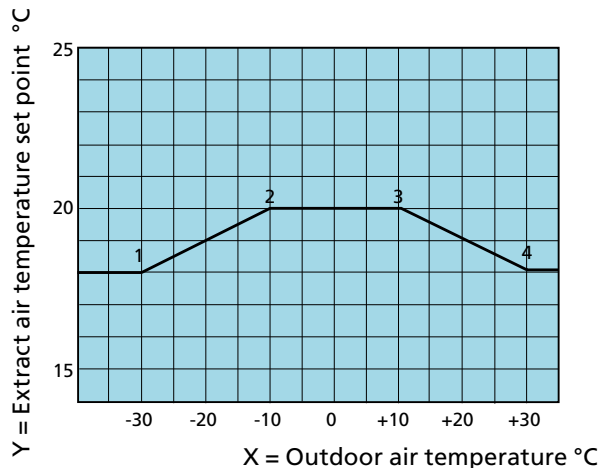

Example:

- If the outdoor air temperature is under -30 °C (X1), the extract air temperature set point will constantly be 18 °C (Y1).
- If the outdoor air temperature is between -30 °C (X1) and -10 °C (X2), the extract air temperature set point is regulated from 18 °C (Y1) up to 20 °C (Y2) as shown in the curve.
- If the outdoor temperature is between -10 °C (X2) and +10 °C (X3) the extract air set point will constantly be 20 °C (Y3).
- If the outdoor air temperature is between +10 °C (X3) and +30 °C (X4), the extract air temperature set point is regulated from 20 °C (Y3) down to 18 °C (Y4) as shown in the curve.
- If the outdoor air temperature is over 30 °C (X4), the extract air temperature set point will constantly be 18 °C (Y4).

## Description of the functions

### Temperature



#### Night compensation

The function is enabled when a lower temperature set point value is required at night.

The required temperature reduction is set and the time interval for night compensation is programmed via two-time channels.

The function can only be used in combination with supply air regulation or extract air/room regulation

#### Temp displacement

Is used to change the setpoint for supply and extract air temperature. For example, the temperature can be increased or decreased at certain times of the day by means of an external timer or potentiometer.

The accessory, IQlogic+ module, is required.

The setpoint can be influenced  $\pm 5^{\circ}\text{C}$  using external control 0 - 10 V.

#### Neutral zone

The neutral zone prevents the cooling and heating systems from counteracting each other.

The preset neutral zone is added to the set point for heating and the sum of these provides the set point for cooling.

#### Dew point compensated supply air

The function is used in installations with cooling and where the supply air duct is uninsulated.

The moisture content and temperature of the extract air are measured via a humidity sensor to ensure that no condensation forms on cold duct surfaces.

On the basis of the measured values for relative humidity and temperature, the current dew point (the temperature at which the moisture in the air condenses) is calculated.

When the dew point exceeds the supply air temperature, the supply air set point is raised to counteract condensation precipitation.

The air flow can be increased to compensate for any losses in cooling capacity with an increasing supply air temperature.

#### External temperature sensors

A temperature sensor in the extract air duct (accessory) can be wired to the air handling unit's control circuit card. This can be used in conjunction with evaporative cooling and Xzone extract air regulation, for example.

Up to four external room temperature and/or outdoor temperature sensors can be wired to the air handling unit's control circuit card when the internal sensor of the unit does not provide representative values..

A room temperature sensor or an outdoor temperature sensor is required (accessories).

Locate the room temperature sensors in suitable positions to obtain representative measured values.

The air handling unit is controlled in response to a computed mean value of the temperature sensors' readings, alternatively in response to signals from the temperature sensor that measures the lowest or highest value.

# Description of the functions

## Temperature



### Regulation sequence

#### Heat mode

The mutual order for the heating mode regulation sequence can be selected as specified below.

Functions that have not been selected have no effect on the relevant regulation sequence.

- 1 = HX - Extra regulation sequence - ReCO<sub>2</sub> - HC - Reheating - Down regulation of the fan
- 2 = HX - Extra regulation sequence - Reheat - ReCO<sub>2</sub> - HC - Down regulation of the fan
- 3 = HX - Reheating - ReCO<sub>2</sub> - HC - Extra regulation sequence - Down regulation of the fan
- 4 = HX - Reheating - Extra regulation sequence - ReCO<sub>2</sub> - HC - Down regulation of the fan
- 5 = HX - ReCO<sub>2</sub> - HC - Reheating - Extra regulation sequence - Down regulation of the fan
- 6 = HX - ReCO<sub>2</sub> - HC - Extra regulation sequence - Reheating - Down regulation of the fan

#### HX (heat exchange)

The temperature efficiency of the air handling unit's heat exchanger is modulated to provide max. heat recovery.

#### Extra regulation sequences:

Used in the heating mode for air heater (if required), air recirculation damper, etc.

A neutral zone, that permits a lower temperature set point before the output signal is given to the extra regulation sequence, can be set.

#### ReCO<sub>2</sub>:

Recirculated air is variably mixed in up to the lowest permissible supply airflow. Assumes inclusion of an air recirculation section accessory.

#### HC:

HC in the heat pump function starts to produce heating.

#### Re-heat:

Air heater for reheating provides heating capacity.

#### Down regulation of fan:

Down regulation can be selected for supply air only or supply air and extract air.

A neutral zone, that permits a lower temperature set point before the fan speed reduction starts, can be set.

#### Cool mode

The mutual order for the cooling mode regulation sequence can be selected as specified below.

Functions that have not been selected have no effect on the relevant regulation sequence.

- 1 = HX - Cooling boost - Extra reg. sequence - ReCO<sub>2</sub> - HC - Cooling
- 2 = HX - Cooling Boost - Extra reg. sequence - Cooling - ReCO<sub>2</sub> - HC
- 3 = HX - Cooling Boost - Cooling - ReCO<sub>2</sub> - HC - Extra reg. sequence
- 4 = HX - Cooling Boost - Cooling - Extra reg. sequence - ReCO<sub>2</sub> - HC
- 5 = HX - ReCO<sub>2</sub> - HC - Cooling Boost - Cooling - Extra reg. sequence
- 6 = HX - ReCO<sub>2</sub> - HC - Cooling Boost - Extra reg. sequence - Cooling

#### HX (heat exchanger):

The temperature efficiency of the air handling unit's heat exchanger is modulated to provide max. cooling recovery.

#### Cooling Boost (Economy):

Involves increasing the supply air and extract air airflows to convey more cooling energy to the premises. The flow increase takes place between the current flow and the preset max. flow.

A neutral zone, that permits a higher temperature set point before Cooling Boost increases the flow, can be set.

#### Extra regulation sequences:

Used in the cooling mode for air cooler (if required), etc.

#### ReCO<sub>2</sub>:

Recirculated air is variably mixed in up to the lowest permissible supply airflow. Assumes inclusion of an air recirculation section accessory.

#### HC:

HC in the chiller function starts to produce cooling.

#### Cool:

Air cooler provides cooling capacity.

### Min. exhaust air (rot. heat exch. only)

The min. exhaust air function can be used whenever the exhaust air temperature is not permitted to be below a predetermined value.

The function controls the heat exchanger rotor speed (efficiency) in order to limit the exhaust air temperature to the required value. The function decelerates the heat exchanger rotor speed from the current level, until the exhaust air temperature reaches the preset minimum permissible setting.

Exhaust air regulation requires a separate temperature sensor (accessory) fitted in the AHU's exhaust air.

# Description of the functions

## Temperature



### Heating boost

Heating boost (forced heating) means that the air handling unit, operating in the normal flow regulation mode, increases both the supply airflow and the extract airflow in order to carry more heat into the premises.

The fans are permitted to operate in the range between current flow modes or pressure (low speed, high speed) and the preset max speed.

If demand control or boost is selected in combination with "Heating Boost", the flow is controlled by the function that transmits the highest output signal to the fans.

When the supply air temperature is 3 degrees (preset at factory) lower than the set max. supply air temperature, the air flow increases gradually to the set max. speed.

### Cooling boost

Cooling Boost (forced cooling) means that the air handling unit increases the supply air and extract air airflows from normal flow in order to convey more cool air to the premises.

The fans are permitted to operate in the range between current flow modes or pressure (low speed, high speed) and the preset max speed.

The function can be selected in seven variants as follows:

#### Comfort

The cooling outputs are activated if there is a cooling load.

When the supply air temperature is 3 degrees (preset at factory) higher than the set min. supply air temperature, the air flow increases gradually to the set max. speed.

#### Economy

Cooling Boost Economy initially uses a higher airflow to cool the premises, before a start signal is transmitted to chillers.

The function can also operate without the cooling function activated.

In the event of a cooling load, the airflows are slowly increased up to preset maximum flow. When the flows are up to max and if a cooling load is still present, the output contacts for cooling are activated.

The function requires that the outdoor air temperature is at least 2 degrees lower than the extract air temperature for it to be activated.

### Sequence

The Cooling Boost Sequence is used if a chiller is sized for a higher cooling flow than normal flow.

If there is a cooling load, the flow is increased up to the preset max. flow and the cooling function is activated afterwards.

The Cooling Boost Sequence is blocked if no cooling function has been selected.

### Comfort and economy

The comfort variant and the economy variant can be combined. When free cooling is available, the economy function is active; if free cooling is not available, the comfort function is active.

### Economy and sequence

The economy variant and the sequence variant can be combined. When free cooling is available the economy function is active. When free cooling is not available the sequence function is active.

### Sequence and comfort

The sequence variant and the comfort variant can be combined. The function that has the highest signal (highest setpoint) applies.

### Comfort, economy and sequence

The comfort variant, economy variant and the sequence variant can be combined. The function that has the highest signal (highest setpoint) applies.

# Description of the functions

## Temperature



### Intermittent night heat

The AHU is utilized for heating the premises when it is normally stopped by timer.

The function requires an external room sensor, and that the air handling unit is connected to an air heater for re-heating. The function works best if the GOLD is equipped with an air recirculation section and shut-off dampers for the outdoor air and the exhaust air.

When the function is activated, the air handling unit detects when the room temperature drops below the preset start temperature.

The air handling unit starts with a set air flow/pressure and the supply air temperature set point. The air handling unit stops again when the room temperature reaches the set stop temperature.

The function then starts and stops the air handling unit intermittently until the timer switches to ordinary low/high-speed operation.

If the extract air fan is not required to operate, the extract airflow can be set to 0.

The damper output can be set to 0. This means that connected dampers (e.g. shut-off dampers for outdoor air and exhaust air) are not affected. These dampers are normally closed when the AHU is stopped and accordingly they remain closed. At the same time, the damper in the air recirculation section opens, if one is installed.

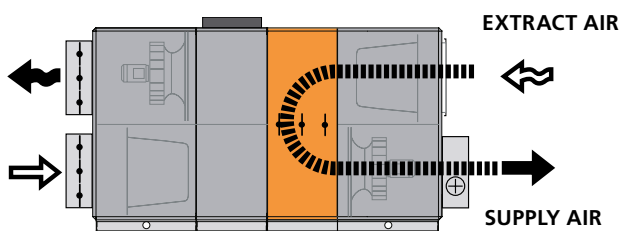

*Intermittent night heat with air recirculation section:  
When conditions for start are met, outdoor air and exhaust air shut-off dampers remain closed. The damper in the air recirculation section is opened. The extract air fan is idle.  
The supply air fan operates according to the preset supply airflow and the air heater for reheating operates according to the preset supply air temperature set point, until the conditions for stop are met.*

### Morning Boost

The unit is used to heat the premises to the ordinary room temperature over a set time prior to the switch-in time set on the timer.

The function is used if an air recirculation section is installed and ideally together with the intermittent night heating function.

The AHU starts up ahead of time and uses the same temperature regulation settings. The airflow / air pressure is adjustable.

When the function starts, the air recirculation damper opens and the supply air fan starts up. The extract air fan and the outdoor air damper remain closed.

### Summer night cool

The lower temperature at night is utilised to cool down the building structure. This reduces the cooling load during the first hours of the day. If a cooling unit is installed, it will not need to be operated, thus offering savings. If no cooling unit is installed, a certain cooling effect will still be achieved.

In order for summer night cooling to start, a specific number of conditions and temperature limits must be met.

When the function is activated, the air handling unit runs at the set air flow/pressure, with the supply air set point 10 °C (factory setting) and from the preset time until the conditions necessary for stop are satisfied.

### Down regulation (airflow/pressure)

Down regulation of the supply air flow is the last step in the regulation sequence for heating.

This function can be selected in cases when an air heater is not installed, or when the air heater is not sized to cover the entire heating requirement.

The supply air fan or both the supply air and extract air fan can be selected. The extract air fan only cannot be selected.

# Description of the functions

## Time and schedule



### Time and schedule

The built-in timer, which has year and week functions, enables you to control the air handling unit's operating mode/time. Certain other oversteering functions such as external timer, communication, etc. affect the preset operating modes.

There are five different operating modes:

**Total stop** = The AHU is completely stopped, no internal automatic functions or external control commands can start the AHU.

**Normal Stop** = The AHU has stopped, however all the internal and external automatic functions oversteer the stop.

**Extended Normal Stop** = The AHU has stopped, however all the internal and external automatic functions, with exception of Summer night cool, oversteer the stop.

**Low speed** = The AHU is running at the preset low speed setting.

**High speed** = The AHU is running at the preset high speed setting.

### Time/Date

The current date and time can be set and adjusted if needed. The timer automatically takes leap years into consideration.

The relevant region and city can be selected, summer time/winter time changeover will then be managed automatically.

Time source can be set to manual or via SNTP (requires connection to network) and BACnet. The time format and date format can be set.

### Schedule settings

Under Schedule setup, you can set an operating mode base level, at which the air handling unit always operates during non-programmed time, under Day schedule and Exceptions schedule.

It is also possible to select a specific period (date interval, weekday or time interval) when the Day schedule and Exceptions schedule shall apply. At other times, outside the selected period, the air handling unit operates at the preset base level.

### Day schedule

Times and days can be set when the unit is to run in the high speed mode, low speed mode or be switched off.

For every day (Monday - Sunday) six different events can be set to occur at a given point in time. Here, it is also possible to set six different events for two exceptions.

### Exceptions schedule

The times, when possible exceptions shall apply, are determined in the Exceptions schedule. Here you can determine on which date or weekday the relevant exception shall apply. It is also possible to associate both exceptions to Calendar 1 or 2. See next section.

### Calendar 1 and 2

The specific days or date interval when Exceptions schedule 1 or 2 shall apply can be set in Calendars 1 and 2. On condition that Calendar 1 or 2 is selected, see previous section. In other cases, these settings will have no effect.

There is a total of ten possible settings under each calendar and various functions can be selected for each.

### Prolonged operation

The control unit inputs for external low speed and external high speed respectively, can be supplemented with Prolonged operation. They can be used for overtime running activated by a pushbutton, for example.

There is an integrated timer function for the external inputs. These can be set separately for overtime operation (low/high speed) in hours and minutes.

## Description of the functions

### Energy monitoring



#### General

Consumed and recovered power and energy are shown via the GOLD air handling unit's hand-hand terminal and the embedded web page.

Accumulated energy consumption can be reset to zero.

All values are also presented in the log graph and are saved on the control equipment's built-in SD card.

Communication offers the opportunity to forward values to a master supervisory system.

The function is included as standard.

#### Supply and extract air fans

SFP values as well as capacity and power consumption for fans can be read.

#### GOLD RX

Calculated temperature efficiency for the rotary heat exchanger can be read.

Capacity and power consumption for the heat exchanger motors can be read.

Calculated capacity and power consumption for cooling and heating can be viewed.

The rotary heat exchanger can be supplemented with efficiency measurement to obtain the measured values instead of the calculated values.

#### GOLD PX/CX/SD

The heat exchanger must be supplemented with the efficiency measurement function to show efficiency, capacity and power consumption when using a counterflow heat exchanger or coil heat exchanger.

#### Efficiency measurement

If the efficiency measurement function is enabled, the measured temperature efficiency of the heat exchanger, capacity and energy recovery for cooling and heating can be shown.

A low efficiency alarm is included in the function.

The function requires two temperature/humidity sensors that are installed in the extract air and exhaust air (accessory).

#### Air heater/Air cooler

Calculated capacity and power consumption for the connected air heater can be shown.

Calculated sensible capacity and power consumption for the connected air cooler can be shown (GOLD PX/CX/SD requires accessories for efficiency measurement, see above).

#### Extract air fan MIRUVENT

SFP values as well as capacity and power consumption for connected fans can be read.

#### Pulse counter

Collected energy values from up to four external energy meters can be read.

By means of a pulse counter, an external meter with digital pulse output for e.g. electricity, water, gas, etc. can be registered.



## Description of the functions

### Filters

---



#### Filter monitoring

The GOLD unit's filter is supplied with a pressure sensor that continuously measures the filters' current pressure drop. Together with an efficient filter monitoring function, this offers optimum filter utilization.

#### Pre-filters

Prefilters can be used in installations where the extract air or supply air is heavily polluted, in order to prevent the fine filter in the unit from becoming clogged after a short time.

A prefilter including pressure sensor can either be obtained installed in the air handling unit, or as a separate duct mounted prefilter section. If another type of prefilter is used, a pressure sensor can be selected as an accessory for filter monitoring.

#### End filter

An end filter can be used in installations where further filtering of the supply air is required.

An end filter section including pressure sensor can be selected as an accessory. If another type of end filter is used, a pressure sensor can be selected as an accessory for filter monitoring.

#### Reading

Current pressure drop and calculated alarm limit can be read in the hand-held terminal.

#### Alarm limit of the filters

As the filters become soiled, the pressure drop across them increases (the speed of the fans automatically increases to compensate for the resistance caused by the clogged filter medium). The alarm limit must be continuously calculated and automatically changed depending on the current flow. An alarm is initiated when the preset alarm limit for each filter is exceeded. The desired alarm limit can be preset in the hand-held micro terminal.

#### To calibrate the filters

An automatic filter test is activated for measuring the initial pressure drop across the filters in the air handling unit. Calibration is carried out when the unit is commissioned and when the filters are changed.

### Software

---



#### Software

The current program versions for the IQlogic control unit, IQnavigator hand-held terminal and the component units on the communications bus can be viewed and updated from the SD circuit card/USB flash drive.

### Language

---



#### Language

The language desired can be set here. Available languages are Swedish, English (UK and US English), German, French, Spanish, Italian, Norwegian, Danish, Finnish, Portuguese, Czech, Estonian, Hungarian, Dutch, Polish, Russian and Turkish.

# Description of the functions

## Alarm management



### General

GOLD is equipped with a detailed alarm list to indicate operating disturbances such as deviating temperatures, air flows, etc., and to protect the GOLD air handling unit's component parts and electronics against external disturbances such as voltage fluctuations, deviating high operating temperatures and the like. The alarm is also given if a component failure occurs.

All alarms are presented in plain text in the alarm log on the hand-held terminal or the embedded web page. In-depth fault cause and trouble-shooting help are described on the information tab.

Alarms are displayed by a flashing red LED in the hand-held terminal.

Active alarms, pending alarms and alarm history (50 latest) can be viewed in the alarm log.

Type A alarms transmit an alarm signal to the output for alarm relay A. Type B alarms transmit an alarm signal to the output for alarm relay B. Alarms can be forwarded with different priority via these relays.

Alarms with manual resetting can be reset from the hand-held terminal. Alarms that reset themselves automatically will do so as soon as the fault has been remedied. Alarms can also be reset via the communication network.

### Alarm forwarding

All alarms can be forwarded to a master supervisory system via the GOLD air handling unit's different communication interfaces.

Alarms can be forwarded via the GOLD air handling unit's web server and access to an e-mail server.

It is possible to associate up to ten e-mail addresses. For these users it is possible to select individually which types of alarm are to be forwarded (A and/or B alarms).

Other information, such as the air handling unit association and the notes found in the free-text field "Notes" on the web page, are also sent in the e-mail.

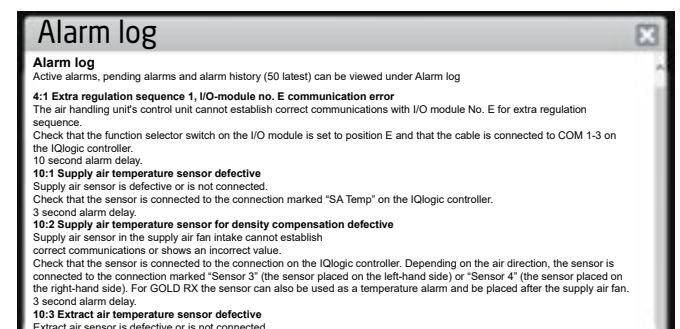
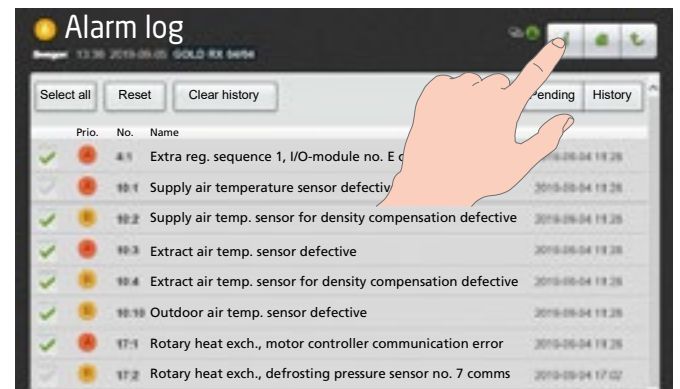

# Description of the functions

## Alarm management



### Fire alarms

#### Internal fire alarm

The air handling unit's internal temperature sensors serve as fire protection thermostats. An alarm is initiated if the supply air temperature sensor registers more than 70 °C or when the extract air temperature sensor registers more than 45 °C. Alarm limits are possible to set.

If an external Extract air/Room temperature sensor is connected and activated, this works parallel with the extract air temperature sensor of the AHU.

#### External fire alarm 1 and 2

Used for external fire-control equipment.

#### Alarm resetting

The resetting of internal fire alarms as well as the external fire alarms 1 and 2 can be individually selected to manual or automatic.

#### After cool

The After cool function for electric air heaters, COOL DX and/or SMART Link DX can be individually activated, for internal fire alarms as well as external fire alarms 1 and 2.

#### Fan operation on a fire alarm

The fans in the air handling unit are tested for one hour of operation at 70 °C and can be used for evacuating gases, etc. It is possible to individually select the type of fan operation for each type of alarm and which fan(s) are to be operating and at what speed.

#### Priority

In connection with fan operation in the event of fire alarms, the mutual priority of the internal and the external fire alarms can be set. If automatic is selected, this means that the first input to be activated is given priority.

#### Fire bypass in flow diagram

The fire bypass is shown on the hand-held terminal's flow diagram when the function is activated. Fan operation for extract air must be active for at least one of the fire alarms. Dampers switch to fire bypass if any of the fire alarms are active and the extract air fan is operational.

#### External alarms

External alarms can be used for external functions.

Typical uses:

- Motor protection for the circulation pump in the heating or cooling circuit.
- Service alarm actuated by smoke detectors.

Set the following: Manual or automatic alarm reset, Delay time for electric air heater and whether the alarm shall be activated on a closed or open circuit. The alarm can be time delayed.

Alarms can be given optional names on the air handling unit's web page.

### Temperature guard

In the GOLD PX and CX units, the sensor in the inlet of the supply air fan can be used as a temperature monitor. The alarm priority and whether the AHU should stop or not in the event of an alarm, can be preset.

It is possible to use a separate sensor for the GOLD RX (accessory).

### Temperature alarm limits

#### Pre-heat below set point

You can preset how much the temperature downstream of the pre-heater should be permitted to be below the temperature set point before an alarm is initiated. The alarm is delayed for 20 minutes.

#### Supply air below/above set point

You can preset how much the supply air temperature shall be permitted to be below or above the supply air temperature set point before an alarm is initiated. The alarm is delayed for 20 minutes.

#### Extract air below the alarm limit

You can preset how much the extract air temperature shall be permitted to be below the extract air temperature set point before an alarm is initiated. The alarm is delayed for 20 minutes.

#### Outdoor temperature, stop limit

The function, outdoor temperature limit, for when an alarm from the heat exchanger can stop the air handling unit.

If the outdoor air temperature is above this stop limit, only an alarm will be initiated and if it is below the stop limit, the AHU will stop and an alarm will be initiated.

### Service period

The air handling unit's service period can be set. The alarm is given when the set time for the service period has expired.

### Alarm priority

For all the alarms, it is possible to select whether the alarm shall have A or B priority. For certain alarms it is also possible to select whether the GOLD unit should stop. Certain alarms can be activated or be blocked.

## Description of the functions

### Log



A large number of the air handling unit's parameters are collected in a log file that is stored on the control card's SD card. It is possible to activate a function that forwards these parameters.

A log-sender function forwards the log file once per day to an optional e-mail address and/or ftp address.

### Air handling unit



#### Settings

The air handling unit can be given a specific name (e.g. the air handling unit's serial number or designation). The given name is then shown in all the images in the hand-held terminal and web page.

The AHU's fan position can be viewed and set.

The fan position in the flow chart can be read and set according to the AHU's actual configuration.

#### Fan status

The fan control speed setting can be viewed in percent of max. speed here.

#### Operation time

In operation times (in days) can if applicable be viewed for fan controls, heat exchanger/cooling recovery, preheating, extra heating regulation sequence, Xzone heating, AHU reheating, ReCO<sub>2</sub> heating, extra cooling regulation sequence, Xzone cooling, AHU cooling, ReCO<sub>2</sub> cooling, AYC heating water and AYC cooling water.

#### VOC/CO<sub>2</sub> sensor

The operating mode of the VOC sensor and the unit for CO<sub>2</sub> can be selected and the VOC level reading can be viewed.

#### Automatic functions

##### Start up sequence

The air handling unit has a start up sequence with a factory-preset time delay between each step as follows:

1. The damper relay is energized and opens the shut-off damper (if installed). The heat exchanger is controlled to max. heat recovery (not the GOLD SD without heat exchanger). The valve for reheating opens to 40% (if installed)

Time delay: 30 seconds.

2. The extract air fan starts in the current operating mode (not for ventilation systems with GOLD SD supply air handling unit only)

Time delay: 60 seconds.

3. The supply air fan starts (not for ventilation systems with GOLD SD extract air handling unit only)

Time delay: 30 seconds.

4. The reheating function is ramped up or down depending on the heating load. Ramp time: 180 seconds. After that the heat exchanger is ramped up or down depending on the heating load. Ramp time: 180 seconds.

The entire start up sequence can be followed in the dashboard image.

The start up sequence prevents the extract air fan from starting up if the shut-off damper is closed. By first starting up the extract air fan and the heat exchanger, you can avoid chilling the premises with supply air on a start up under cold weather conditions.

##### Zero point calibration

The zero value of the pressure sensors is checked to maintain the pressure sensors' measurement accuracy. If the value is not correct, a new calibration is carried out. Engages automatically every time the fans are stopped for more than 70 seconds. The fans cannot start while calibration is in progress.

# Description of the functions

## Heat



### Preheating the air

Preheating the air, if the outdoor temperature is cold and the humidity is high, can prevent condensation from forming in the air handling unit's filters. Preheating may also be necessary to heat the air during extremely cold weather.

The accessories below can be used for the air pre-heat function:

Air heater preheating of the type Swegon (control of the air heater included) or, if another air heater is used, control of air heater preheating of the type Swegon is needed. A valve kit can be used for the water air heater and if a pump is required, the pump set can be used.

The Swegon standard electric air heater can be used together with the air pre-heat control function in an air handling unit installed indoors.

See also the Pre-heat function guide for more detailed information.

### Extra regulation sequences 1 and 2

Used for extra regulation functions controlled by a 0-10 V (10-0 V) signal with ordinary temperature regulation sequence.

The function can be used for utilising existing heating or cooling sources, such as from a chiller. The function can also be used for an extra air heater or air cooler.

It can also be used for controlling dampers for recirculation, if required.

The maximum output signal can be limited from 100% down to 0 %.

The output signal of the extra regulation sequence is controlled from the IQlogic+ module accessory. If both extra regulation sequences 1 and 2 are used, two IQlogic+ modules are required.

When the SMART Link DX function is selected, the extra regulation sequence is automatically activated.

The extra regulation sequence makes it possible to control two air heaters at the same time in the following combinations: water - electricity, water - water, electricity - electricity. The air heater for hot water is available without or without frost guard function.

When the output of the first air heater is not sufficient, the second is automatically brought into the sequence.

A start-up sequence, frost guard function, pump control, exercising of the pump and valves, post-cooling for electric air heater and other functionality are available.

For the start-up sequence, frost guard function, periodic operation and post-cooling, the same settings are used as for regular reheating.

The function can also be used to control a combi coil (heating and cooling). See the next paragraph.

### Combi coils

The combi coils function is used when a coil both cools and heats the air. A common coil, instead of one heating coil and one cooling coil, means the pressure drop in the supply air duct decreases.

The function can be used for water coils in a 2-pipe system (one valve) or 4-pipe system (two valves). It can also be used for a reversible heat pump or a common DX-coil.

The function does not affect the ordinary heating and cooling sequence, these can be used as usual.

When water coils are used, the anti-frost's heat-retaining function is blocked in cooling mode.

A temperature guard for measuring the supply flow temperature can be installed in the water circuit (accessory).

For an activated function and heating requirement, the supply flow temperature must be higher than the supply air temperature in order for the valve to open.

For an activated function and cooling requirement, the supply flow temperature must be lower than the supply air temperature in order for the valve to open.

Control of pumps is possible and there is a pump alarm input.

It is possible to switch between cooling and heating via an external contact function or communication signal.

It is also possible to give a control signal (free normally open contact function) that enables cooling or heating.

It is possible to control, with a stopped air handling unit, at which outdoor temperature the heat retention function shall be permitted to run via an external outdoor temperature sensor (accessory). This temperature limit also controls when the circulation pump should be in continuous operation instead of only starting in the event of a heating requirement.

See also the combi coils function guide for more detailed information.

## Description of the functions

### Heat



#### Re-heat

The electric air heater and valve kit for the water air heater are equipped with a quick-fit connector for connection to the air handling unit's control unit which automatically senses the type of air heater in use.

#### Air heater for hot water

When there is a reheating load, and the the function Periodic operation of pump or of pump+valve is selected, the circulation pump of the air heater starts.

If the outdoor temperature is low, the pump output contact is continuously activated. During other times, the pump output contact is activated 3 min./day (factory setting) for periodic operation of the circulation pump.

#### Frost guard function, air heater for water

The frost guard function is always active if the valve kit for the water air heater has been supplied by Swegon.

The function activates a heating device that keeps the temperature in the coil at 13 °C while the air handling unit is operating and 25 °C in the coil when the unit is stopped. An alarm is initiated and stops the AHU if the temperature sensor senses a temperature below 7 °C.

#### Electrical heaters

If the electric air heater has been in operation, the air heater is post-cooled for about 3 minutes (factory setting) when stop has been activated.

#### Integrated temperature protection electric air heater

Only in combination with Swegon's electric air heater.

The electric air heater is designed to withstand a minimum air velocity of 0.8 m/s at full output.

Integrated temperature protection automatically regulates the output at lower air velocities or at high supply air temperatures.

#### Thermal overload protection, electric air heater

The electric air heater is equipped with two-step thermal overload protection.

The first step is automatic and protects the air heater from overheating.

The second step is manual and trips at temperatures where there is a risk of fire. Manual reset of the air heater.

#### Season Heat

When both the standard function for reheating and the extra heating sequence are activated, it is possible to alternate between these via a digital input or communication.

Example: Hot water is only available in the winter. In the summer, any reheating load is backed up by an electric air heater. Changeover can be done manually or via external thermostat, external clock function or the like. The IQlogic+ module accessory is required.

## Description of the functions

### Heat



#### Xzone temperature regulation

Xzone temperature regulation is used when more than one temperature zone is needed in a ventilation system. Examples of various temperature loads, in various parts of a building, can be the north and south facade of the building or diverse operations.

Both re-heating and cooling can be controlled in the extra zone.

Xzone requires the control box accessory for Xzone.

A standard electric or water air heater can be used.

The valve kit can be used for water air heaters. The pump kit is used if a pump is needed.

The function is designed for one extra temperature zone, max.

The type of temperature regulation should be selected separately for Xzone.

The following choices are possible:

ERS Regulation 1

ERS Regulation 2

Supply air regulation

Extract air regulation

ORS regulation

ORE regulation

If an electric air heater is fitted, there is an alarm function for the overheat guard as well as the air heater after cool function if the air handling unit stops,

If an air heater for water is fitted, it is possible to control the operation of the pump. The settings for exercising will then be common with the main zone.

#### Functions that influence both zones

##### *Electrical heaters*

The after cool time setting is common for the main zone and Xzone.

##### *Summer night cool*

The room temperature sensor is placed in the main zone. The supply air temperature set point is common for both zones,

##### *Intermittent night op.*

The room temperature sensor is placed in the main zone. The settings apply to the main zone. When intermittent night operation is activated, Xzone has the same temperature set point as that used during day operation.

##### *Morning Boost*

Both zones run on the same temperature set point as that used during day operation

##### *Heating boost*

The function is controlled by the main zone only.

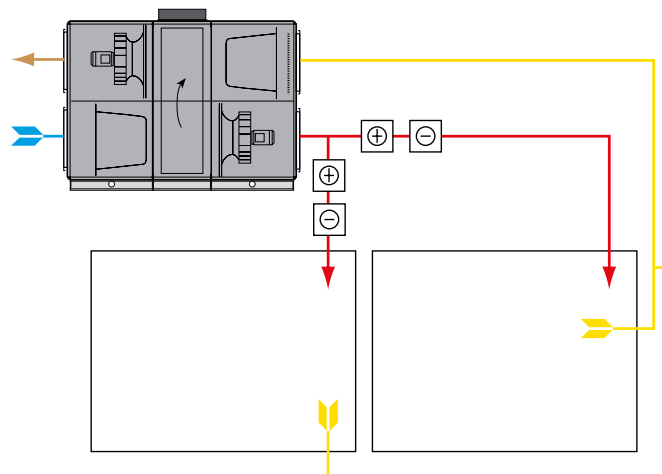

Xzone example

## Description of the functions

### Cool



#### Extra regulation sequences 1 and 2

Used for extra regulation functions controlled by a 0-10 V (10-0 V) signal with ordinary temperature regulation sequence.

The function can be used for utilizing existing heating or cooling sources, such as from a chiller. The function can also be used for an extra air heater or air cooler.

It can also be used for controlling dampers for recirculation, if required.

The maximum output signal can be limited from 100% down to 0 %.

The output signal of the extra regulation sequence is controlled from the IQlogic+ module accessory. If both extra regulation sequences 1 and 2 are used, two IQlogic+ modules are required.

When the SMART Link DX function is selected, the extra regulation sequence is automatically activated.

The extra regulation sequence makes it possible to control two water air coolers at the same time. When the output of the first air cooler is not sufficient, the second is automatically brought into the sequence.

There is functionality for pump control and exercising of the pump and valves. The same settings as for a regular air cooler are used.

The function can also be used to control a combi coil (heating and cooling). For the description, see the heating section.

#### Cool

##### Air cooler, water

The valve actuator of the air cooler for water is equipped with a quick-fit connector for connection to the AHU's control unit which automatically activates the cooling function. The valve actuator is controlled steplessly 0-100% (0-10V) when the cooling load increases. A temperature sensor is connected for reading the water temperature.

##### DX air cooler

###### 1 step

Used when cooling in 1 step is connected. The cooling controller of the AHU regulates the cooling output according to the cooling load, 0-100 %. The cool relay is energized when cooling is required.

###### 2 steps

Used when cooling in 2 steps is connected. The cooling controller of the AHU regulates the cooling output according to the cooling load, 0-100 %.

Cool relays 1 and 2 are energized in sequence when cooling is required.

###### 3 steps binary

Used when cooling with two inputs controlled with three binary steps is connected. The cooling controller of the AHU regulates the cooling output according to the cooling load, 0-100 %.

Cool relays 1 and 2 operate in binary mode. Cool relay 1 is energized first and on increased cooling load cool relay 1 is de-energized and cool relay 2 is energized. Both cool relays 1 and 2 are energized on a full cooling load.



# Description of the functions

## Cool



### Xzone temperature regulation

Xzone temperature regulation is used when more than one temperature zone is needed in a ventilation system. Examples of various temperature loads, in various parts of a building, can be the north and south facade of the building or diverse operations.

Both re-heating and cooling can be controlled in the extra zone.

Xzone requires the control box accessory for Xzone.

Standard air cooler for water and DX air cooler can be used.

The valve kit can be used for air coolers for water. The pump kit is used if a pump is needed.

The function is designed for one extra temperature zone, max.

The type of temperature regulation should be selected separately for Xzone.

The following choices are possible:

ERS Regulation 1

ERS Regulation 2

Supply air regulation

Extract air regulation

ORS regulation

ORE regulation

If an air cooler for water is fitted, it is possible to control the operation of the pump. The settings for exercising will then be common with the main zone.

### Functions that influence both zones

#### Summer night cool

The room temperature sensor is placed in the main zone. The supply air temperature set point is common for both zones,

#### Cooling boost

The function is controlled by the main zone only.

#### Cooling, min. flow

The cooling min. flow function applies to the flow from the air handling unit, not the flow for each zone. When the total flow reaches below the preset value, cooling will be blocked in both zones.

## COOL DX

### COOL DX - Economy

Used when the COOL DX chiller is connected.

The cooling unit regulates the cooling requirement in three binary steps.

Low/high pressure for each compressor can be read.

Stop limit and alarm limit for low/high pressure are set at the factory for each compressor.

### COOL DX - Comfort

Used when the COOL DX chiller is connected.

The cooling unit regulates the cooling requirement in three binary steps.

The heat exchanger in the AHU operates in sequence with the cooling unit to even out the supply air temperature.

Low/high pressure for each compressor can be read.

Stop limit and alarm limit for low/high pressure are set at the factory for each compressor

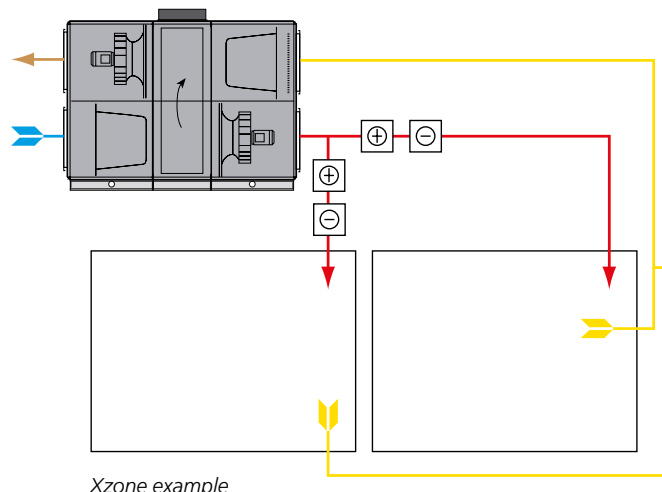

### COOL DX Top

Used when the COOL DX Top chiller is connected.

The cooling unit regulates the cooling requirement in three binary steps.

Low/high pressure for each compressor can be read.

Stop limit and alarm limit for low/high pressure are set at the factory for each compressor.

The placement of the air cooler allows cooling recovery to be used.

### Delay time

The restart time, step switch time and stop/start times can be set for cooling relays and COOL DX.

### Drying function

The drying function can be activated to prevent condensation water from remaining in the air cooler when the air handling unit has stopped.

If the air cooler has been in operation when the stop is activated, the air cooler is re-dried for 3 minutes (factory setting).

### Outdoor air limits

Provision is available for setting an outdoor temperature-related blocking function in three steps.

If the outdoor temperature is below each step limit, the function of the cooling step will be blocked. The function is used for preventing the relevant compressors from being switched on and off too many times.

The function can be used for cooling relays and COOL DX.

### Air flow limits

The cooling function is blocked if the supply or extract airflows are lower than the preset limit.

For step-regulated cooling, it is possible to set an air flow related blocking function in three steps. If the air flow for the supply air or exhaust air is below each step limit, the function of the cooling step will be blocked.

The function can be used for cooling relays and COOL DX.

# Description of the functions

## Heat exchange

### Control

#### GOLD RX

The rotary heat exchanger starts up in the event of a heating load. If the heating load increases, the control system regulates the rotation speed of the heat exchanger rotor, variably and linearly to maximum heat recovery.

#### GOLD PX

The bypass damper closes and the shut-off damper opens when heat recovery is required. This is performed steplessly to max. efficiency on heat recovery.

#### GOLD CX/SD (coil heat exchanger)

The pipework package's pump starts and the regulating valve opens when heat recovery is required. The regulating valve opens steplessly to max. efficiency on heat recovery.

#### Efficiency optimization

For optimal efficiency, the pressure controlled pump is regulated so that the liquid flow is optimized with respect to the extract air flow.

The glycol type and glycol content used in the coil heat exchanger are taken into account.

### Carry over control

If the fans are generating low air flows, the rotary heat exchanger is decelerated to an appropriate speed to ensure a correct purging air flow through the heat exchanger.

### AQC, Air Quality Control (rotary heat exchanger)

The Air Quality Control (AQC) function is used to guarantee that the heat exchanger's direction of air leakage and the purging sector work correctly.

Negative pressure in the extract air section must not be greater than in the supply air section. This ensures that extract air will not be transferred to the supply air.

In systems where variable flows and pressure variations occur, the function cannot be guaranteed with the ordinary supplied commissioning plates.

A pre-adjustment is made using the ordinary commissioning plates and a damper with a modulating damper actuator mounted in the extract air.

A separate pressure sensor measures the pressure difference across the heat exchanger and controls the extract air damper so that the right pressure balance is obtained across the heat exchanger.

### Efficiency measurement

The efficiency measurement for the heat exchanger, for RX/PX/CX, requires two extra sensors (accessory). The sensors are placed in the exhaust air and extract air and measure temperature and moisture.

Measured values are specified under the humidity function.

### Defrost (rot. heat exch.)

In environments where the extract air can occasionally be humid, the defrosting function can be activated to protect the heat exchanger from frosting. The function continuously monitors the condition of the heat exchanger rotor to prevent it from becoming clogged due to condensate that has frozen inside the exchanger.

The function requires the connection of a separate pressure sensor.

When the defrosting function is activated the pressure drop across the heat exchanger is continuously measured and the reading is compared with the calibration reading. If the pressure drop exceeds the preset limit value, a defrosting sequence is implemented in which the rotor speed is gradually ramped down to as low as 0.5 rpm. During the defrosting process, the warm extract air thaws any possible ice that has formed on surfaces.

Note that the heat exchanger performs less efficiently while defrosting is in progress and that the supply air temperature will also drop downstream of the heat exchanger.

Connection principle for the defrosting function with separate pressure sensor.

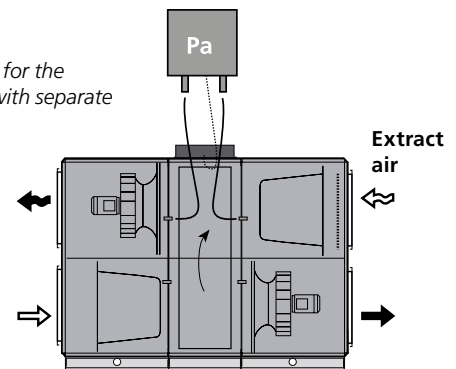

Principle of the Air Quality Control (AQC) function.

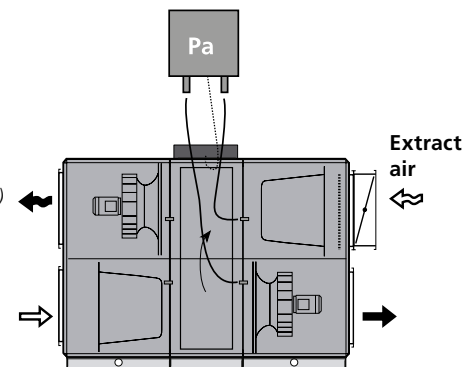

# Description of the functions

## Heat exchange



### Automatic functions

#### **GOLD RX (rotary heat exchanger)**

##### *Purging operation*

The air purging function prevents clogging of the heat exchanger's air ducts. It switches in when the unit is operating but there is no heating load and the heat exchanger rotor is idle. The heat exchanger rotor then rotates for 10 seconds every 10 minutes to perform purging.

##### *Calculation of the efficiency*

The efficiency is calculated and displayed (0 – 100%).

##### *Calculation of recovered energy*

Recovered sensible energy is calculated and the values are displayed (instantaneous and accumulated).

##### *Cooling energy recovery*

The heat exchanger rotates at max. speed in order to recover the relative cooling energy available inside the premises. It engages when there is a cooling load and when the outdoor air temperature is higher than the extract air temperature. It cannot be used with the CoolDX cooling unit.

##### *Overtime heat exchanger operation*

If the AHU stops, the heat exchanger automatically continues to recover heat for about 1 minute. It takes a little time for the fans to stop rotating after a stop has been ordered and this prevents the supply air from chilling the premises.

##### *Rotation monitoring*

The rotation monitoring in the motor control system continuously monitors the heat exchanger. If a malfunction forces the heat exchanger to stop, an alarm is initiated and the air handling unit is stopped if the outdoor temperature is low.

##### *Reading of internal leakage*

The internal leakage can be read on the hand-held terminal and on the web page. Reporting is done according to EN 16798-3.

OACF (Outdoor Air Correction) shows the relation between the outdoor air/supply air.

EATR (Exhaust Air Transfer) shows the transfer of exhaust air to supply air.

#### **GOLD CX/SD (coil heat exchanger)**

##### *Pump control, coil heat exchanger*

The pump of the pipework package starts when heat recovery is needed. If heat recovery is not needed for more than 24 hours, the pump is exercised once a day.

##### *Anti-frost protection*

In cold weather, and if the extract air is humid, there is risk of frosting in the coil heat exchanger. The GOLD CX/SD is equipped with anti-frosting protection.

The temperature of the liquid circulated to the extract air coil and the humidity in the extract air are measured.

Taking the humidity into consideration, the control system calculates the lowest permissible temperature without risk of frosting inside the coil. The valve in the pipework package is then regulated to prevent the circulated liquid from dropping below this temperature.

#### **GOLD PX (counterflow heat exchanger)**

In cold weather, and when the extract air is humid, there is risk of frosting inside the counterflow heat exchanger. The GOLD PX is therefore equipped with anti-frost protection.

##### *RECO Frost anti-frost protection*

The pressure drop across the heat exchanger, extract air temperature, moisture content in the extract air and outdoor air temperature are measured.

With consideration given to the pressure drop across the heat exchanger, the extract air temperature, the moisture content in the extract air and the outdoor air temperature, the control system individually regulates dampers for bypass and the heat exchanger for section-by-section defrosting without the formation of frost.

The bypass function is calibrated to maintain the same supply air flow irrespective of the operating mode (normal mode or defrosting).

When operational the section defrosting provides a high temperature efficiency, which reduces the capacity requirement for air heater.

Section defrosting is adaptive and the defrosting cycle is adapted to the prevailing weather conditions and prerequisites.

##### *Spring/autumn energy optimization*

When there is no need of full heat recovery, the first dampers above the heat exchangers are controlled to open gradually. When the damper above the heat exchanger is fully open, the bypass damper is regulated to close.

In this way, the pressure drop above the heat exchanger is reduced during the spring/autumn and gives less fan energy consumption.

# Description of the functions

## HC



### Control

The HC function is used to control a reversible heat pump in the air handling unit GOLD RX/HC.

The reversible heat pump circuit is controlled with three signals:

- Stop/Start (0/1)
- Heating/Cooling (0/1)
- Speed level compressor as a percentage (25 - 100% for GOLD RX/HC size 011 - 030, 12.5 - 100% for GOLD RX/HC size 035 - 080)

For more information regarding reversible heat pumps, see the function guide reversible heat pump RX/HC.

### Use

All settings and operating information occur via the GOLD air handling unit's regular hand-held terminal.

All alarms, refrigerant circuit's different temperatures and pressure as well as other operating status for the reversible heat pump can be read on the hand-held terminal.

The outdoor temperature limits for heating and cooling as well as air flow limits are possible to set on the hand-held terminal.

### Temperature control

The heat pump has its own control sequence in the GOLD air handling unit's temperature sequence. The sequence regulates the temperature requirement 0-100%, for the heating and cooling sequence respectively.

### Comfort function

The comfort function is possible to select for heating and/or the cooling function.

If the comfort function is selected and the temperature requirement is low, comfort mode is enabled. Operation of the reversible heat pump is then locked to a lowest level of the compressor speed. The rotary heat exchanger is allowed to regulate to maintain the required supply air temperature. If instead the temperature requirement exceeds the lowest level of the compressor speed, operations return to normal mode.

### Defrost

The pressure drop across the exhaust coil is measured to detect the defrosting requirement.

Start and stop of the defrosting process is controlled by calculations, which take a number of different factors into consideration that are measured continuously. Adaptation is performed after each defrosting to optimise the process.

There are four options to defrost the exhaust coil (for the heat pump function), see below and the diagrams to the right.

- Reversing the refrigerant circuit.
- Reversing the refrigerant circuit + Electric air heater
- Reversing the refrigerant circuit + Air recirculation section RX/HC
- Reversing the refrigerant circuit + Electric air heater + Air recirculation section RX/HC

For sizing, the product selection program AHU Design proposes suitable defrosting options for the specific operating case.

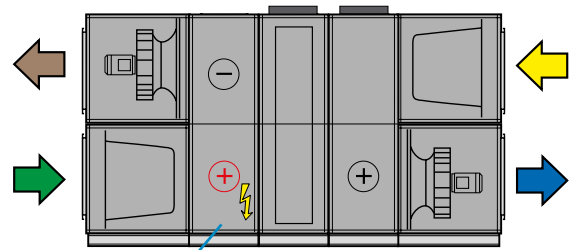

Electrical air heater placed in RX/HC (accessory)

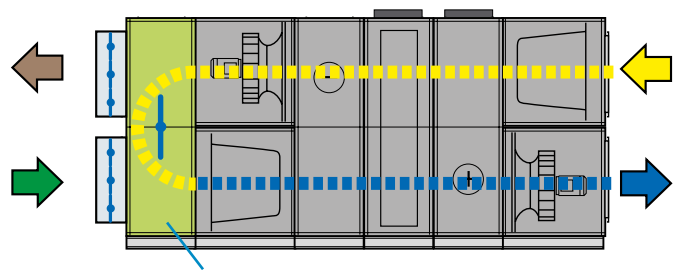

Air recirculation section RX/HC (accessory)

Outdoor air Supply air Extract air Exhaust air

## Description of the functions

### SMART Link



#### SMART Link

The SMART Link function is intended for use for optimum control of the temperature and operation as well as the reading of alarms and the values for a Swegon chiller/heat pump.

For more information concerning waterborne heat pumps chillers, see the Guide to the SMART Link/AQUA Link Functions.

#### Energy-saving functions (waterborne)

*Verification of the supply air temperature/inlet flow temperature*

By comparing the supply air temperature downstream of the fan with the inlet supply temperature of the water entering the coil, the equipment sees to it that the valve of the coil only opens if water has a temperature that will furnish energy to the air passing through the coil.

This means that if heating is required and the water temperature is lower than the supply air temperature, which can occur during defrosting cycles, the valve is not permitted to open. The reverse applies if cooling is required.

*Optimisation function*

A chiller/heat pump becomes more efficient if the difference between the outdoor temperature and the water temperature is as small as possible. This reduces energy consumption.

The supply of energy to a water coil is controlled by a valve. Optimizing the valve's position, so that it always strives to be fully open, and instead controlling the water temperature, offers energy savings.

*AQUA Link*

AQUA Link supplies chilled water to both air handling units and comfort modules. Even here, energy savings can be achieved by letting the cooling load control the water temperature.

Depending on which need exists (dehumidification, cooling the supply air, cooling the rooms via comfort modules), the temperature of the cooling water can vary and the controller ensures that the chiller will not produce colder water than necessary.

# Description of the functions

## SMART Link



### SMART Link+

The SMART Link+ function is intended to join Swegon's waterborne cooling units and heat pumps to the GOLD air handling unit. The function optimises the production of heating and cooling energy.

Communication occurs via Modbus/TCP. All functionality is included in the software for individual products, no extra control equipment is needed. SMART Link+ saves time during installation, saves energy and offers a user-friendly interface.

Up to ten GOLD air handling units can be connected to two heating producers and two cooling producers of the Omicron, Zeta, Tetris, Kappa and Omega.

All controls in GOLD for liquid-borne heating and cooling can be freely combined and used in the function. Controls for Xzone, All Year Comfort (AYC) and combi coils are also included.

One control sequence can be freely connected to an external heating/cooling producer, for example, district heating or district cooling.

For more information about SMART Link+, see the function guide for SMART Link+

### Optimisation function

A chiller/heat pump becomes more efficient if the difference between the outdoor temperature and the liquid temperature is as small as possible. This reduces energy consumption.

The supply of energy to a liquid-borne air cooler/air heater is controlled by a valve. Optimising the valve's position, so that it always strives to be fully open, and instead controlling the liquid temperature, offers energy savings

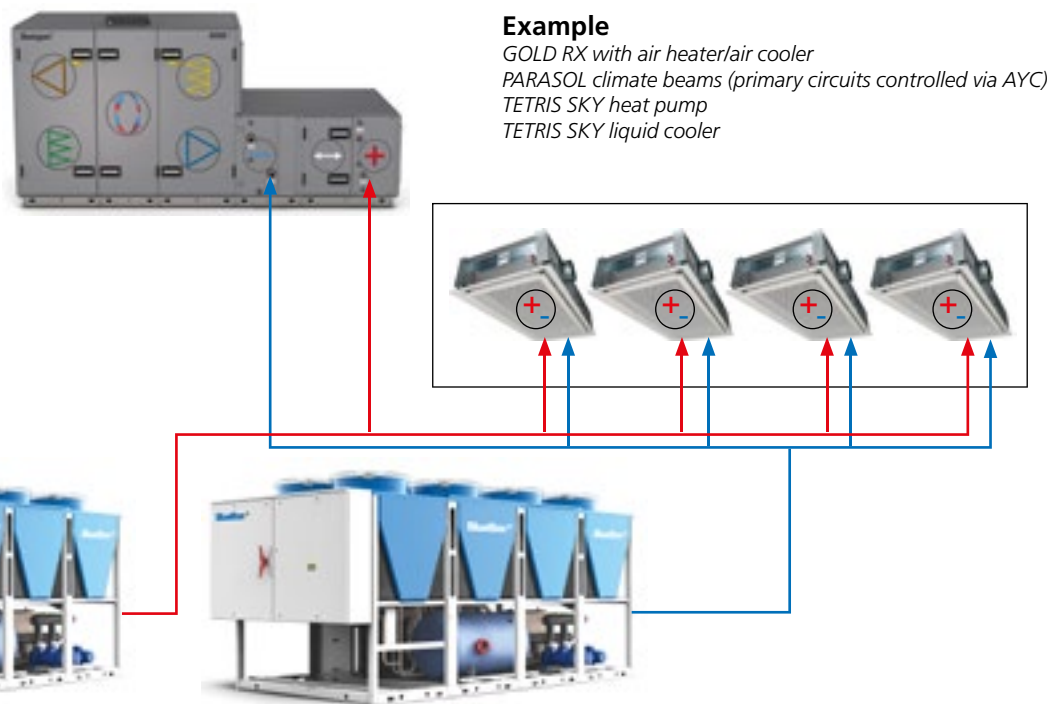
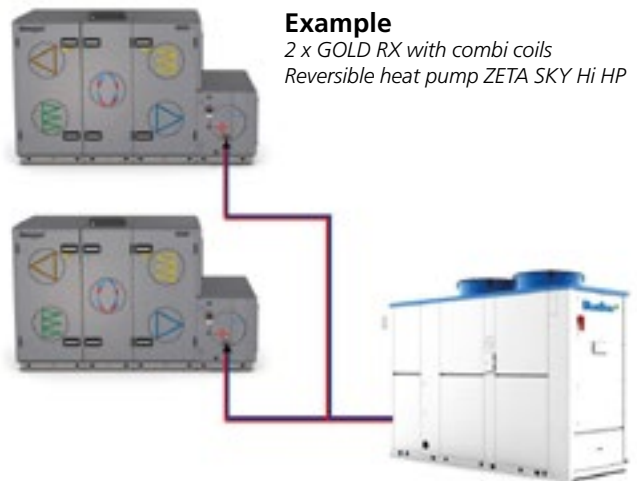

# Description of the functions

## Humidity



### Humidifying

#### Evaporative humidification (On/Off)

This function is suitable together with an evaporative humidifier (not included in Swegon's standard range).

The function requires the IQlogic<sup>+</sup> module accessory and 1 humidity sensor, see separate installation instructions. Install the humidity sensor in the extract air duct or in the premises, see the illustration.

The humidity in the extract air duct/premises is regulated between adjustable start and stop limits.

A weekly timer with four time channels makes it possible to switch between two configurable start and stop limits.

Note that if evaporative humidification is used, this will also influence the supply air temperature. When sizing an air heater, you must take this into consideration.

#### Steam humidification (0 - 10V)

The function is appropriate for operation together with a steam humidifier (not included in Swegon's standard range) and is a variable control system via 0-10 V control signal, as well as a contact function which interlocks the humidifier if the air handling unit stops, if Summer night cool is used or if the humidity in the supply air exceeds the set point by more than 10%.

The function requires the accessories IQlogic Plus module and 1 humidity sensor (for supply air regulation) or 2 humidity sensors (for extract air regulation), see separate installation instructions.

Install the humidity sensors in the extract air duct or in the room as well as in the supply air duct, see the drawing.

The function keeps the humidity level constant in the extract air duct or room by regulating the humidity in the supply air.

In order to prevent the humidity in the supply air from being too high, it is restricted to a maximum limit.

Alternatively the humidity in the supply air duct can be kept constant by selecting a regulating humidity sensor in the supply air.

A weekly timer with four time channels makes it possible to switch between two set points.

If the vapour humidifier is equipped with an electricity meter with digital pulse output, the energy consumption can be reported in the GOLD air handling unit's hand-held terminal and built-in web page. The function requires the pulse counter accessory.

#### Humidifier alarm

The alarm input can be selected to closed circuit, open circuit or contactor function.

### Dehumidifying

The function is intended for dehumidifying the supply air in order to prevent condensation in the supply air duct or in connected air conditioning products.

The dehumidification regulation function controls the humidity in the supply air duct or the extract air duct by means of an air cooler and an air heater for reheating.

The function requires that an air cooler be mounted upstream of the air heater in the supply air duct. See the example to the right.

The humidity sensor (accessory) shall be mounted in the supply air duct or the exhaust air duct and shall be connected to the air handling unit.

Cooling energy is emitted to condense the moisture in the supply airflow, which then is heated to the desired supply air temperature. This causes a reduction in the moisture content of the supply air.

The cooling unit used must be sized so that the temperature of the supply air will be below the dew point, otherwise no condensation will arise and no dehumidification will occur.

### Hygrostatic rotor controller

The function is designed to recover and maintain indoor humidity in an efficient and controlled way, so that a good indoor climate can be achieved. In cases where additional humidification is required, the function can be supplemented with any of the above humidification functions.

Controlling the speed of the heat exchanger, taking into account the humidity of the room and the outdoor air, allows the optimisation of moisture recovery.

In winter, a drying function can be activated to avoid temporarily high humidity indoors.

The function requires the GOLD air handling unit to be equipped with a RECOsorptic rotary heat exchanger and five humidity sensors located in the outdoor air, supply air, room, extract air and exhaust air.

See also the Hygrostatic rotor controller function guide.

#### Example, steam humidification

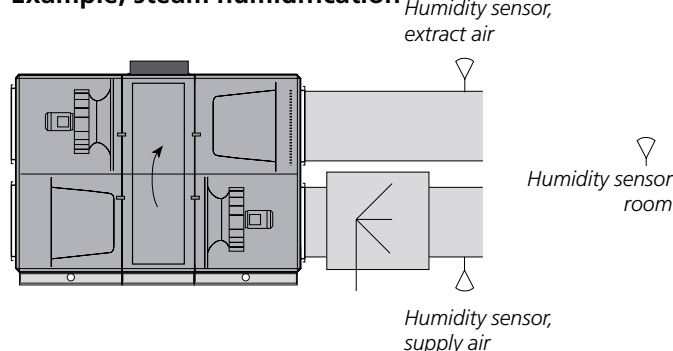

#### Example: Dehumidifying regulation

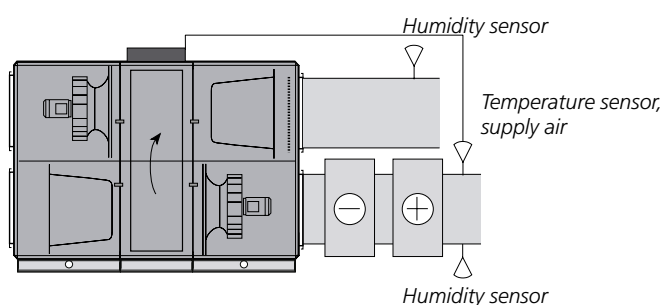

## Description of the functions

ReCO<sub>2</sub>

ReCO<sub>2</sub>

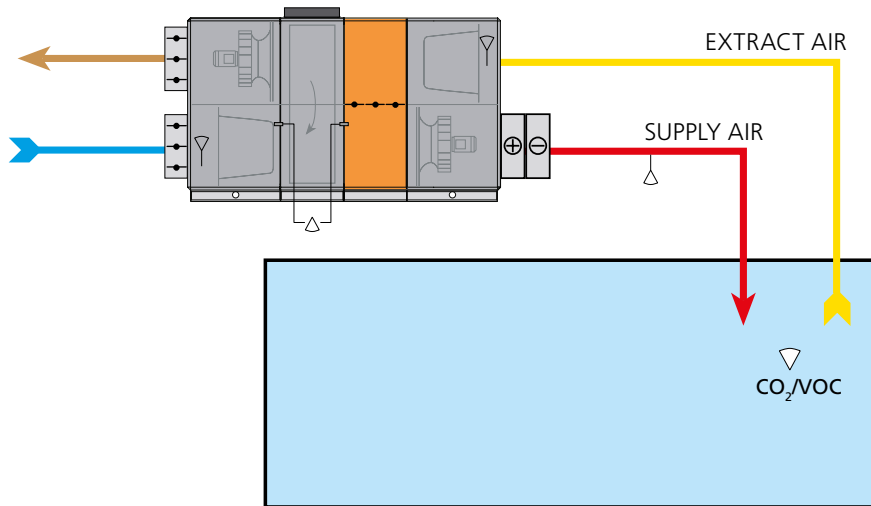

The ReCO<sub>2</sub> function is designed for ensuring the correct air quality or air temperature, by means of recirculating extract air and minimizing the inflow of outdoor air.

The function can be preset for checking the CO<sub>2</sub>-/VOC content and/or temperature.

Lower outdoor air and exhaust air flows as well as lower extract air fan speed enable the unit to consume less power.

The function presupposes that the outdoor air damper and the damper in the air recirculation section are equipped with modulating damper actuators.

The function requires a pressure sensor (accessory) to measure the pressure drop across the heat exchanger. The outdoor air flow is calculated on the basis of readings of the pressure drop across the heat exchanger.

The CO<sub>2</sub>/VOC function also requires the air quality sensor accessory or VOC sensor.

For more information, see the ReCO<sub>2</sub> function guide.

**CO<sub>2</sub>/VOC.** The setpoint of the outdoor air flow is reduced, if the air is of sufficiently good quality. The recirculation damper is opened first for intermixing recirculated air. If the outdoor air flow is still too high when the recirculation damper is completely open, the outdoor air damper begins to close.

The control adjusts the flow setpoint of the extract air fan down to the same percentage as the outdoor air flow, in order to maintain the balance between the exhaust air and outdoor air.

If the air quality becomes worse, controller first opens the outdoor damper and then closes the recirculation damper.

**CO<sub>2</sub>/VOC+ boosting air flow.** Works in the same way as ReCO<sub>2</sub> – CO<sub>2</sub>/VOC, except that the increase in flow is added in the control sequence.

If the air quality still isn't adequate, when the outdoor air damper is fully open and the recirculation damper is fully closed, the air flow setpoint is increased for both the supply air and the extract air fans. This increases the air volume in order to achieve a higher rate of air change with outdoor air.

**Temperature.** Control of the recirculation damper can be set for cooling sequence, heating sequence or both, and to work before or after reheating/cooling control.

**CO<sub>2</sub>/VOC and Temperature.** Control can be preset to regulate both air quality and temperature simultaneously. If air quality or temperature becomes controlling depends on which of them requires the largest outdoor air volume.

The Heating Boost and Cooling Boost functions can be activated if increased supply air flow for a heating or cooling load is required.



# Description of the functions

## All Year Comfort

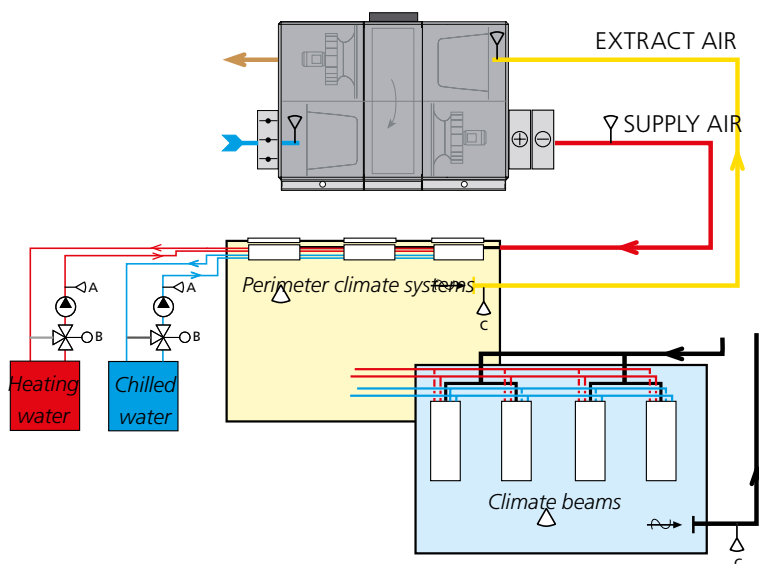

The All Year Comfort function is designed for controlling the primary water circuit for supplying chilled water and/or heated water to climate beams, perimeter climate systems, etc..

This function requires a separate equipment cubicle (accessory). This function also requires the extract air humidity sensor accessory for dew-point regulation.

Other necessary equipment can be valve actuators, 3-way valves, circulation pump, etc.

The function keeps the chilled water and hot water temperature constant at the required setting in the connected cooling and heating systems respectively.

Two strap-on temperature sensors measure the water temperature (see A in the figure above). The sensors are fitted on the water pipe downstream of the regulating valve (see B in the figure above).

See also Dehumidification control under Humidity.

For more information, see the All Year Comfort Function Guide.

### Outdoor compensation

To make it possible to adapt the primary water circuit temperature to the design of the building and the outdoor temperature, the supply flow temperature's setpoint must be adjusted in line with the outdoor temperature according to an adjustable performance curve. The curve can be adapted to various conditions by means of four adjustable points.

### Room compensation

In the event of an extra cooling or heating load, the supply flow temperature for the cold or hot water respectively can be adjusted.

Setpoint for the supply flow temperature is influenced by the room temperature. The setpoint for regulating the hot water is reduced when the room temperature exceeds the preset limit value. The setpoint for regulating the cold water is increased when the room temperature drops below the preset limit value.

Night blocking makes it possible to block the function at night.

### Night compensation

If the premises are not utilised at night and on weekends, the water temperature can be adjusted in order to save energy.

The supply flow temperature setpoint is decreased (heating circuit) or increased (cooling circuit) during the preset period.

It is possible to set two periods for night and weekends respectively via two time channels.

### Dew point compensation (cooling water only)

The moisture content and temperature of the extract air (see C in the figure above) are measured in order to ensure that no condensation forms on cold metallic surfaces.

On the basis of the measured values for relative humidity and temperature, the current dew point (the temperature at which the moisture in the air condenses) is calculated. When the dew point exceeds the cooling water temperature, the cooling water setpoint is raised to counteract condensation precipitation.

To compensate for any losses in cooling capacity in the event of an increasing cooling water temperature, the airflow can be increased to extract more surplus heat.

### Pump/valve

The pump for the heating circuit is started and stopped according to preset outdoor limit temperatures.

The pump for the cooling circuit is operated together with the GOLD unit and is stopped when the air handling unit is shut down. It is also possible to stop the pump for the cooling circuit if the outdoor temperature is below the preset setpoint.

The alarm for the pumps can be monitored, and the valves can be monitored by means of an alarm in the event the valve position is incorrect.

In order to prevent the pumps and valves from becoming clogged, in the event of a prolonged period of downtime, they can be exercised at preset time intervals.

## Description of the Functions

### MIRU



#### MIRUVENT – GOLD

Power roof ventilator MIRUVENT can be connected to a GOLD air handling unit. The control equipment of the GOLD unit is fully pre-programmed for controlling the MIRUVENT.

Below is a description of what functions are possible to act upon/obtain information about, via the GOLD unit hand-held terminal or via communication with a main control system. The individual functions are described in more detail in the catalogue for MIRUVENT.

#### Control

Up to three power roof ventilators can be connected to one GOLD air handling unit by means of bus communication. Two or more connection kits (accessory) containing a cable adapter and a communication cable are required depending on the number power roof ventilators.

It is possible in the hand-held terminal to select whether the power roof ventilator should be controlled in parallel with the GOLD unit, and whether it should follow the low-speed/high-speed operating modes of the air handling unit.

All the time channels can be set separately for each connected power roof ventilator via the GOLD unit hand-held terminal.

It is also possible to control externally the power roof ventilators stop/low/high from e.g. a timer or other external signal (requires the accessory IQlogic+).

#### Balanced ventilation

The balanced ventilation function can be used if the power roof ventilators are used for variable flow. It is then possible to select which power roof ventilator(s) is/are to be included in the function.

In the case of balanced extract air, all the air flows of the activated power roof ventilators are added together. The extract air flow in the GOLD unit is decreased by the corresponding volume. In this way the supply air flow will be the same as the total extract air flow and balanced ventilation will be achieved inside the building.

In the case of balanced supply air, all the air flows of the activated power roof ventilators are added together. The supply air flow in the GOLD unit is increased by the corresponding volume. In this way the supply air flow will be the same as the total extract air flow and balanced ventilation will be achieved inside the building.

The function presupposes that accessory pressure sensors for flow measurement and possible pressure regulation are connected.

#### Flow/pressure regulation

Depending on the function selected, it is possible to set the desired set point for pressure or flow, low speed and high speed, in the GOLD unit hand-held terminal.

#### Status

The following values can be read in the GOLD unit hand-held micro terminal for each power roof ventilator:

Air flow\*. Duct pressure\*. Current set point for flow/pressure\*. Temperature\*. SFP. Power. Power consumption in kWh. Operating mode. Common fault alarm 0/1. Alarm from the connected sensors and type of alarm from MIRUVENT's motor control.

*\*Shown depending on which sensor is connected to MIRU.*

## Description of the Functions

### MIRU



#### Temperature compensation

The air flow temperature compensation mode can be activated if it is desirable to displace the air flow as a function of the outdoor air temperature or the room air temperature.

In the flow regulation mode, the current setpoint for air flow is offset. In the pressure regulation mode, the current setpoint for pressure is offset.

The function requires an outdoor air sensor (accessory) to be connected to the GOLD air handling unit

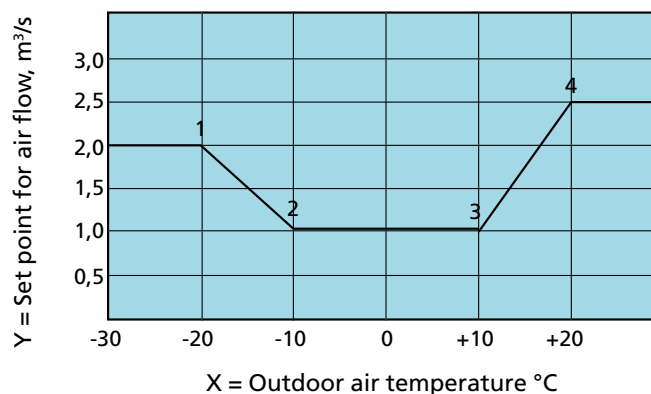

#### Example:

*Flow regulated power roof ventilator. The same principle can be applied to a pressure regulated power roof ventilator. However this will cause a reduction in pressure in Pa.*

*If the outdoor air temperature is below -20 °C (X1), the flow set point will be a constant 2.0 m³/s (Y1).*

*If the outdoor air temperature is between -20 °C (X1) and -10 °C (X2), the air flow will decrease from 2.0 m³/s (Y1) to 1.0 m³/s (Y2) as shown in the curve.*

*If the outdoor air temperature is between -10 °C (X2) and 10 °C (X3), the flow set point will be a constant 1.0 m³/s (Y2 and Y3).*

*If the outdoor air temperature is between 10 °C (X3) and 20 °C (X4), the air flow will increase from 1.0 m³/s (Y3) to 2.5 m³/s (Y4) as shown in the curve.*

*If the outdoor air temperature is over 20 °C (X4), the flow set point will be a constant 2.5 m³/s.*

#### Communication

When the power roof ventilator MIRUVENT is connected to the GOLD unit control equipment, this also offers you the opportunity of communication with a main control system via Modbus TCP, Modbus RTU, Exoline or BACnet IP for all the connected power roof ventilators.

You can then read and set the values for pressure and flow. All of the time channels can be set for each power roof ventilator. Provision for viewing the energy, temperature and common fault alarm readings.

# Description of the functions

## Inputs / Outputs

I/O

### External supervision

Can for example be used if the air handling unit will be controlled/monitored via microprocessor substation or a PLC system.

Up to two IQlogic+ modules (accessory) can be used for external operating functions. Up to three IQlogic+ modules (accessory) can be used for external communication via BACnet, Modbus or Exoline (module A/B/C).

### Outputs

#### Digital outputs

Each IQlogic+ module has two relay-controlled outputs.

These functions can be selected in the hand-held terminal.

With an IQlogic+ module, a maximum of two of the functions below can be combined as standard. With an additional IQlogic+ module the number of combinations can be increased to four:

- Air handling unit in operation
- Air handling unit in auto operation
- Air handling unit in manual operation
- Air handling unit in low speed operation
- AHU operating in high speed mode
- A-alarm
- B-alarm
- Damper relay
- Heat exchange
- Heat exchange defrost
- Re-heat
- Re-heat power reduction
- Heating boost
- Morning Boost
- Intermittent night op
- Air flow down regulation
- Extra reg. sequence 1, heat
- Extra reg. sequence 1, cool
- Cooling
- Cooling Boost
- Summer night cool
- Supply air fan in operation
- Extract air fan in operation
- Internal fire alarm tripped
- External fire alarm 1
- External fire alarm 2
- External fire alarm 1 or 2
- Any fire alarm
- External fire alarm 1, with priority
- External fire alarm 2, with priority
- Internal fire alarm triggered with priority
- Preheating
- HC defrosting
- HC defrosting with recirculation
- HC heat
- HC cool
- Filter calibration

#### Analogue outputs

Each IQlogic+ module has two analogue outputs. These indicate current supply air and extract air flows respectively.

### Inputs

#### Digital inputs

Each IQlogic+ module has two digital inputs.

These functions can be selected in the hand-held terminal.

With an IQlogic+ module, a maximum of two of the functions below can be combined as standard. With an additional IQlogic+ module the number of combinations can be increased to four:

- Alarm reset.
- Cooling water regulation AYC, external stop.
- Hot water regulation AYC, external stop.
- MIRU 1-3 external stop
- MIRU 1-3 external low speed
- MIRU 1-3 external high speed
- Reheater alarm input
- Cooling alarm input 1
- Cooling alarm input 2

#### Analogue inputs

Each IQlogic+ module has two analogue inputs.

These functions can be selected in the hand-held terminal.

With an IQlogic+ module, a maximum of two of the functions below can be combined as standard. With an additional IQlogic+ module the number of combinations can be increased to four:

- Temperature setpoint displacement.
- Setpoint displacement supply air flow.
- Setpoint displacement of extract air flow.

### External communication module A/B/C

IQlogic+ modules for external communication can be used and controlled completely separately by the monitoring system (BMS). Do not affect the GOLD unit's internal control system.

There are one AI, one AO, one DI, one DO and two inputs for temperature sensor on every IQlogic+ module. The temperature sensor should be of Swegon manufacture.

The function can be activated in the AHU's hand-held terminal or via a communication interface.

## Description of the functions

### Communication



#### Communication

Provision for communication and supervision is integrated as standard into GOLD.

Communication with the intelligent building system can be established via two different interfaces, Ethernet or EIA 485.

The following protocols can be obtained as standard without an extra communication unit: Modbus TCP, Modbus RTU, Metasys N2, Exoline and BACnet IP.

#### Communication via embedded web server

The GOLD has an embedded web server that makes it possible to communicate with the air handling unit via a network.

You then access to the same view management and the possibility to settings, reading and visualization as in the GOLD air handling unit's hand-held terminal, and an e-mail function with up to ten users for forwarding alarms.

All that is needed is a computer with web browser, such as Internet Explorer, Chrome, Safari and others.

#### Wi-Fi

The AHU's control unit is, as standard, equipped with Wi-Fi function and can be connected to e.g. a portable computer or smart phone.

The same view management and the possibility to settings, reading and visualization as in the GOLD air handling unit's hand-held terminal.

All that is needed is a web browser, such as Internet Explorer, Chrome, Safari and others.

#### Communication via intelligent building system

The scope available for communication is conditional on the software and its programming. The GOLD unit in itself offers possibility for overall communication of readings, settings and functions.

Further information about interfaces, protocols and configuration is available at [www.swegon.se](http://www.swegon.se) (com).



Example of a flow chart from the built-in web server.

# Description of the functions

## Base setting



### Base setting

Used for saving, loading and restoring the settings.

### Commissioning record, general

A commissioning record can be created via the GOLD air handling unit's web page as well as a pdf document once installation and commissioning of the air handling unit has been completed.

Depending on the authorization level of the person logged in (installation or service), the available parameters are presented for each level.

### Commissioning record, details

A number of details about location, customer, address, etc. are entered in on the web page. There is a free text field for notes. These details are included when the record is created.

### Commissioning record, design

The commissioning record contains only the functions and parameters that are active for the specific air handling unit. The commissioning record can also be saved locally on the control equipment's SD card.

### Air handling settings/ communication settings

The AHU's settings/communication settings are saved/loaded to/from the control unit's internal memory or external SD circuit card/USB flash drive that can be inserted into the control unit.

Date and time for the latest saved backup copy can be viewed.

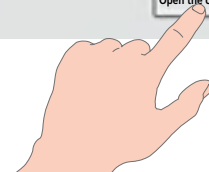
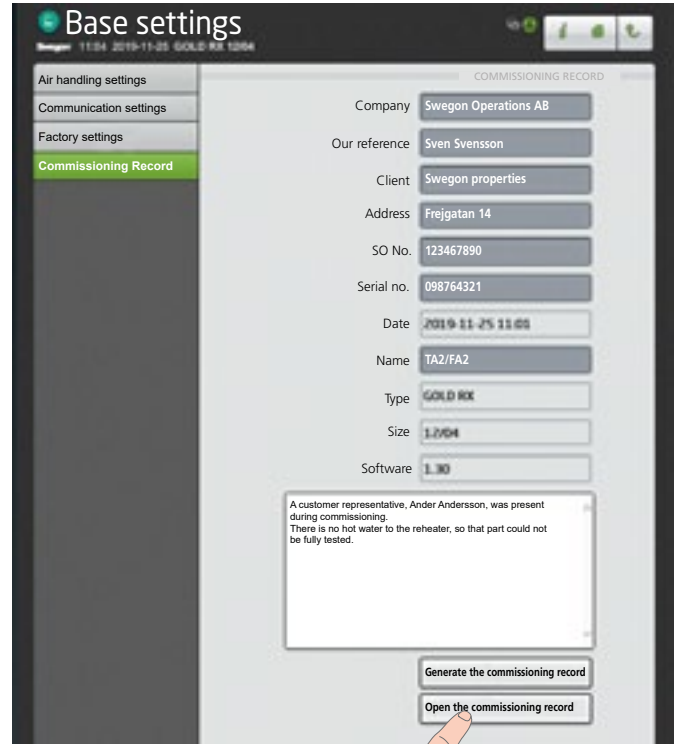

## Description of the functions

### Manual test

---



#### Manual test

Manual test operation can take place for testing the inputs and outputs, fans and heat exchanger, etc.

Used for installation or troubleshooting to test that wired connections and functions operate correctly.

Only accessible via the hand-held terminal (not the web-page).

### IQnavigator

---



#### IQnavigator (hand-held terminal)

The backlight brightness of the hand-held micro terminal can be set to four different settings (Auto/Low/Medium/High) and button sound effects can be activated and have five volume settings.

Only accessible via the hand-held terminal (not the web-page).

### File manager

---



Files on the SD card can be handled in the file manager. Log files, air handling settings and communications settings can be saved or deleted, for instance.

The SD card should be placed in the air handling unit's control circuit card (not the hand-held terminal).

