

GLOBAL PX

Ventilation unit with plate heat exchanger - TAC6



Ventilation unit with counterflow heat exchanger, for commercial installations.
Suitable both for new construction and when renovating existing buildings.

Max. airflow 6800 m³/h (1890 l/s).

Temperature efficiency above 90% (-10°C/+22°C).

Temperature efficiency above 83% according to EN 308.

Energy-efficient and quiet EC fans with fan impeller made of composite material or aluminium.

For installation indoors or outdoors.

Top quality control system with touch screen.

Units up to GLOBAL PX 08 have external dimensions that allow passage through a door.

Swegon 

HIGHLY EFFICIENT VENTILATION UNIT WITH ENERGY RECOVERY

Each project has unique parameters and must satisfy different requirements. That is why Swegon offers a wide selection of air handling units and always has a solution to match your needs.

The GLOBAL series includes fans equipped with high performance direct-current motors (Total Airflow Control) that meet the most stringent requirements regarding energy performance, such as the ErP2018. The latest control system (TAC) is at the technical forefront, thanks both to its internal functionality and its open communication (Modbus, TCP/IP, BACnet, KNX).

PLUG-AND-PLAY UNIT

The GLOBAL ventilation units are supplied as plug-and-play units. The basic functions are factory programmed and the accessories are installed, connected and configured prior to delivery from the factory. When the display has been connected, you only need to turn on the power to the unit and, if necessary, alter the preconfigured parameter values.

ACCESSIBILITY FOR MAINTENANCE

The unit has large inspection doors that make the maintenance work easier. All components, including bypass dampers and actuators, are easily accessible and can be cleaned with mild detergent.

FANS

The direct-driven EC fans have fan impellers made of composite material as standard. Aluminium fan impellers are available as an option. The benefits of composite fan impellers are their low weight and more aerodynamic form, which results in low noise levels and provides the fan with lower specific fan power (SFP). The impellers are made of bio-polyamides that are fully recyclable. Both the fans are located on the cold side of the plate heat exchanger, which further reduces the supply air system's noise level. The fan motor is of the EC type (electronically commutated) with an integrated EC control unit. The motor conforms to enclosure class IP 54. The powerful EC fans ensure that sufficient external pressure is available, even at higher airflows. The efficiency conforms to the requirements in ErP2018. The fans are dynamically balanced in accordance with ISO 1940, class G6.3.

FREE COOLING

Adjustable bypass flow, up to 100%, is a standard function in GLOBAL units with counterflow heat exchangers. This makes the free cooling function possible and is regulated automatically based on the indoor and outdoor temperature. The bypass function can also be configured for defrosting the heat exchanger.

HEATER

The GLOBAL units can be supplied with a factory-fitted, built-in, water heating coil or electric post-heater. The heater's output is adjusted in order to maintain a constant temperature.

DAMPERS

The GLOBAL units can be supplied with factory-fitted, motor-driven outdoor air and exhaust air dampers. In units fitted with dampers, the TAC control unit activates a fan start delay when the unit is started up. Spring return actuators are available as optional equipment. For units with a circular connection, the dampers are supplied separately.

AIR FILTERS

The GLOBAL units are supplied with bag filters made of glass fibre. The function of the filter is to keep both the air and the heat exchanger free from contaminants. As standard, the outdoor air filter has filter class ePM1 \geq 70% and the extract air filter has ePM10 \geq 55%. Extract air filters of class ePM1 \geq 70% are not available as an option, as this would have a detrimental impact on energy efficiency. The filters are installed in lockable guide rails to make filter changing and cleaning of the filter section easier. The filter guide rails satisfy the requirements for airflow leakage according to filter class F9/ePM1 \geq 80% (EN 1886). The filter monitoring function is integrated in the TAC control unit's standard configuration.

Pre-filter of class G4/COARSE, installed inside the air handling unit, can be ordered as an optional extra. A pre-filter is used when the outdoor air is heavily contaminated, in order to prevent the fine filters in the GLOBAL unit from clogging up unreasonably quickly. All filters are classified in accordance with both ISO EN 16890 and ISO EN 779, and are Eurovent certified: 08.10.44.

CONTROL UNITS

The integrated control system TAC is connected to HMI TAC-touch, a 4.3" capacitive touch screen. The air handling units can be configured and controlled from the touch screen.

SAT MODBUS for configuration, indication and display as well as controlling the operation of the unit via MODBUS RTU.

SAT KNX for configuration, indication and display as well as controlling the operation of the unit via KNX.

SAT Ethernet for configuration, indication and display as well as controlling the operation of the unit via MODBUS TCP/IP.

BACnet gateway for configuration, indication and display as well as controlling the operation of the unit via BACnet IP.

SAT Wifi for configuration, indication and display as well as controlling the operation of the unit via wireless communication.

CHARACTERISTICS

- EN1886 classification: T3/TB2/F9/L2/D2.
- Eurovent certified heat exchanger with high temperature efficiency.
- Built-in electrical or water post-heating coil available as an option. Fully integrated control system.
- HMI with intuitive commissioning menu and integrated, context-based assistance.
- EC plenum fans with fan impellers made of composite material for high efficiency and low noise levels. Aluminium fan impellers are available as an option.
- All doors can be hung on hinges on both sides. This makes it easier to access all components, including in installations where space is limited.
- Made of galvanised sheet steel painted in colour RAL7016, with 50 mm mineral wool insulation.
- Robust design with aluminium profiles.
- Designed so that it can be dismantled and reassembled on site.
- Circular duct connections with rubber seal (05/08/10).
- Plug-and-play unit with complete electrical connections. The unit and all the accessories are installed, connected and configured prior to delivery from the factory.
- Filter class ePM1 70% for outdoor air and ePM10 55% for extract air. Class G4 pre-filter for outdoor air intake available as an option.
- Base frame with openings facilitates transport and handling at the installation site.
- The base frame is 125 mm high and has 48 mm lifting holes.
- Installation and detailed work of high quality; the hinge's closing force and alignment can be adjusted.
- Tried and tested, preconfigured TAC control unit.
- Software for unit selection is available online.
- ERP2018-optimised design.
- Conforms to the requirements in hygiene standard VDI6022.
- Conforms to the requirements in standard ISO EN 16890.
- Conforms to the requirements in standard ISO EN 16798-3.
- Units up to GLOBAL PX 08 have external dimensions that allow passage through a door.

OPTIONAL EXTRAS

- Built-in electric post-heater
- Built-in water post-heating coil
- External post-heater/cooler
- Motor-driven dampers
- Flexible duct connection : circular or rectangular (20/30 mm)
- Slip clamp 20 mm



THE CORRECT OPERATING MODE IS IMPORTANT

AIRFLOW OR PRESSURE

Whether the ventilation system is to work with constant pressure, with a constant airflow or be controlled with voltage signal 0–10 V from a control system is dependent on the application and the requirements stipulated by the installation in question. The built-in control system ensures that the operation is always well-balanced.

CONSTANT AIRFLOW

This operating mode is often used in buildings that do not require variable airflows, such as office buildings and commercial properties, schools, daycare centres, sports halls, etc., where the airflow requirement is relatively stable.

DEMAND CONTROL

Alternatively, the airflow can be adjusted automatically according to the ventilation requirements and the wishes of the users with the aid of the 0–10 V signal input, for example with a CO₂ sensor or with the customer's automated building management system or equivalent.

CONSTANT PRESSURE

This operating mode is very well suited to premises where you ideally want to have the potential to control the airflow individually in the various rooms. A pressure sensor ensures that the pressure remains constant, even when the airflow is increased or decreased in accordance with the ventilation requirement in the room.

The airflow remains unchanged in all the other rooms, i.e. the ventilation system works constantly within its optimum operating range. Constant pressure operation requires an external pressure sensor.

THE 3 OPERATING MODES

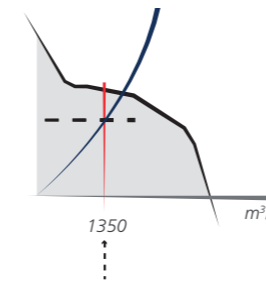

Constant airflow

The airflow is kept constant, regardless of changes in pressure.

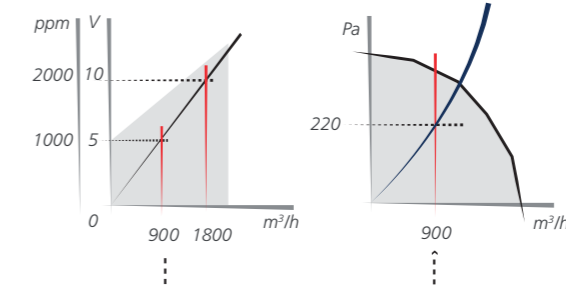

Demand control

The airflow is a linear function of the control voltage. The airflow is regulated with a control voltage of 0–10 V.

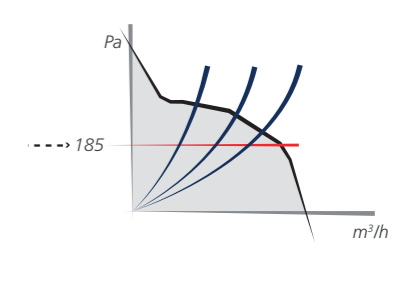

Constant pressure

The pressure is kept constant, regardless of changes in the external pressure. Constant pressure operation requires an external pressure sensor.

CONTROL UNIT ALTERNATIVES

TACTOUCH HMI

HMI with an LCD display and built-in timer control of 6 events per day. All parameters can be set and the unit can be controlled via the touch screen. Commissioning menu, alarm history, operating parameters and error messages are presented in plain text.

4-MODE SELECTOR

With the 4-mode selector, the unit can be set to one of its three configured operating speeds, or be turned off.

SAT MODBUS

Interfaces for configuration, indication and display as well as controlling the operation of the unit via MODBUS RTU.

SAT ETHERNET

Interfaces for configuration, indication and display as well as controlling the operation of the unit via MODBUS TCP/IP.

BACNET GATEWAY

For communication with the ventilation unit via BACnet TCP/IP protocol. The interface can handle up to four units. BACnet gateway requires the installation of the SAT Ethernet interface.

SAT WIFI

Wifi interface that, together with the TAC control unit, facilitates wireless communication with the air handling unit. The Wifi interface is normally used when you want to control the unit from a mobile phone.

SAT KNX

Interfaces for configuration, indication and display as well as controlling the operation of the unit via KNX.

SAT IO

SAT IO is a satellite circuit, intended to be mounted on the main control card. It is used to expand the number of inputs and outputs.



GLOBAL PX – GENERAL

CIRCULAR DUCT CONNECTIONS

The duct connections for sizes 05 and 08 are circular and are fitted with a rubber seal. The units can be combined with motor-driven dampers.

RECTANGULAR DUCT CONNECTIONS

The standard duct connections (15 mm) for size 12 and above are rectangular. For units with rectangular duct connections, there are several options: rectangular/circular adapter, 20 mm slip-clamp connections or 30 mm sleeve connections (METU). The units can be combined with motor-driven dampers and flexible duct connections.

FIRE BYPASS

GLOBAL PX can be used for smoke evacuation in the event of a fire. With fire bypass as an optional extra, the unit is supplied with an extra duct opening that can be used to evacuate smoke via the extract air fan without passing the filter and the heat exchanger. The unit is supplied without a fire/smoke damper, and an external fire control system is required to control these. TAC does not have the functionality to control fire/smoke dampers. GLOBAL's fans are tested for a temperature of 70°C for one hour.

CASING

The GLOBAL unit's casing has a frame made of aluminium profiles, held together by plastic corner pieces. The casing panels are a 50 mm thick sandwich construction made of sheet steel with intervening mineral wool insulation. The outer sheet steel is painted in colour RAL7016, while the inner sheet steel is galvanised. The doors are hung from four hinges supplied with handles, two on either side. The doors can therefore be opened in both directions.

Casing data according to EN1886:

Air leakage class: L2 (R)

Thermal bridges: TB2

Thermal transmittance: T3 (Optimised insulation as optional extra)

Mechanical strength: D2 (M)

Airflow leakage filter: F9/ePM1 ≥ 80 %

EC FANS WITH FAN IMPELLERS MADE OF COMPOSITE MATERIAL

The EC fans have fan impellers made of composite material as standard, which provides the fan with lower specific fan power (SFP). The benefits of composite fan impellers are their low weight and more aerodynamic form. Aluminium fan impellers are available as an option.

BASE FRAME

A base frame is pre-installed under all GLOBAL units. The base frame is self-supporting. The frame is 125 mm high and is fitted both with 48 mm lifting holes for lifting with a crane as well as with notches for forklift truck forks.

COUNTERFLOW HEAT EXCHANGER

The plate heat exchanger, which is a counterflow type, is made of salt-resistant aluminium and has a high temperature efficiency, above 90%. The bypass damper is regulated based on both the heating and the cooling requirement, and can be used as anti-frost protection. In order to reduce the risk of freezing up, the heat exchanger block is not installed horizontally. The incline makes the draining of condensation easier, thereby reducing the risk of ice forming in the heat exchanger. The heat exchangers are Eurovent certified (certificate no. 05.03.243) and VDI 6022 certified.

BUILT-IN WATER POST HEATING COIL

The unit can be equipped with a built-in waterborne air heater. The heater is placed downstream of the heat exchanger. The water heating coil has built-in water connections and is supplied with flexible connections made of stainless steel in order to connect to the existing water system outside the unit. The water heating coil is fitted with a temperature sensor for freeze protection, installed on the surface of the heater. Three-way valve and actuator are supplied with the heater.

BUILT-IN ELECTRIC AIR HEATER

GLOBAL units with a counterflow heat exchanger can be supplied with a factory-fitted, built-in electric pre-heater and/or post-heater. The post-heater's output is adjusted in order to maintain a constant supply air or extract air temperature. The pre-heater's output is adjusted in order to prevent water from freezing in the heat exchanger. The electric heater has two overheating protection units, one with manual resetting and the other with automatic resetting. When stopping the unit, the electric heater is immediately turned off, but the fans continue to run for 90 seconds to cool the heater.

EXTERNAL AIR HEATER/COOLER

The GLOBAL units can be configured with external heaters/coolers, fitted in an insulated casing. Water-based or directly expanding (DX) heaters/coolers can be used. Its output is adjusted in order to maintain a constant supply air or extract air temperature. The waterborne unit is supplied ready-to-connect, such as a 3-way valve, which is controlled from the TAC control unit. With the TAC control system, GLOBAL units can control any combination of heater/cooler (water or DX) for cooling alone, heating alone or cooling and heating in sequence.

CONTROL UNIT TAC

The control equipment is fully integrated in the GLOBAL units. The control unit monitors and regulates temperatures, airflows and other functions. The control unit is pre-configured with standard values on delivery from the factory. Many built-in functions are included in the system and are easy to activate. The air handling units can be regulated automatically in several different ways, with the aid of the built-in timer control or with the main control system, but also with the aid of e.g. a CO₂ sensor. Manual control is also possible.

HMI

User-friendly 4.3" touch screen. The interface includes a menu that makes commissioning easy and intuitive. The touch screen has a 2-metre long connection cable and a magnetic bracket, which means that it can be attached anywhere on the unit. The set values are stored in the memory, which means they are not lost in the event of a power failure.

EC PLENUM FAN MADE OF COMPOSITE MATERIAL
(ALUMINIUM IS AVAILABLE AS AN OPTION) 1

BAG FILTER FOR OUTDOOR AIR, CLASS F7
(PRE-FILTER CLASS G4 AVAILABLE AS AN OPTIONAL
EXTRA) 2

BUILT-IN CONTROL UNIT 3

HINGES FOR GOOD ACCESSIBILITY 4

BASE FRAME DESIGNED SIMPLE TRANSPORT 5

HIGHLY EFFICIENT PLATE HEAT EXCHANGER 6

BUILT-IN POST-HEATER (WATER HEATING/ELECTRIC) 7

FIRE BYPASS 8

BAG FILTER FOR EXTRACT AIR, CLASS M5 9

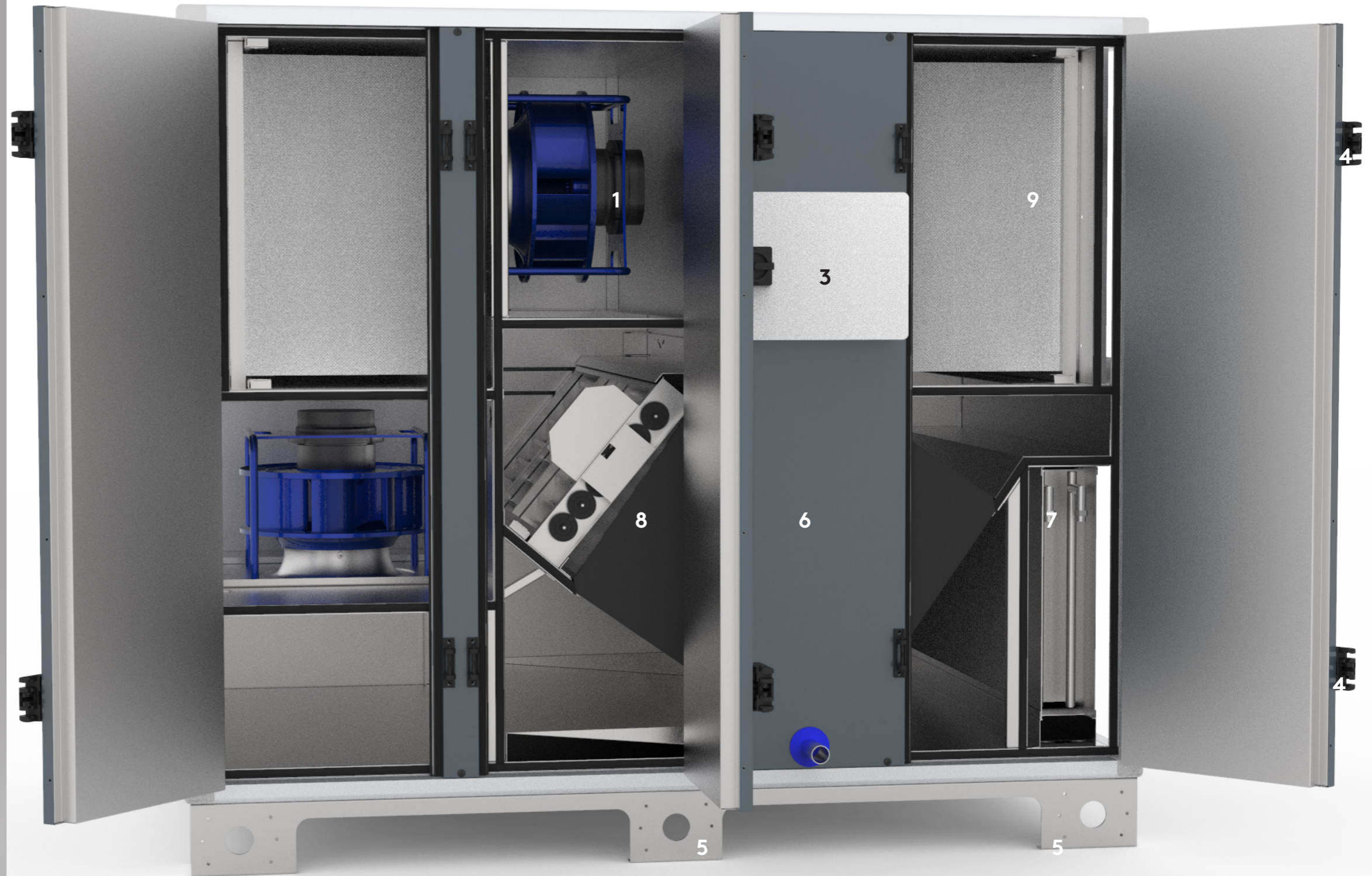

GLOBAL PX 04

FAN DIAGRAMS

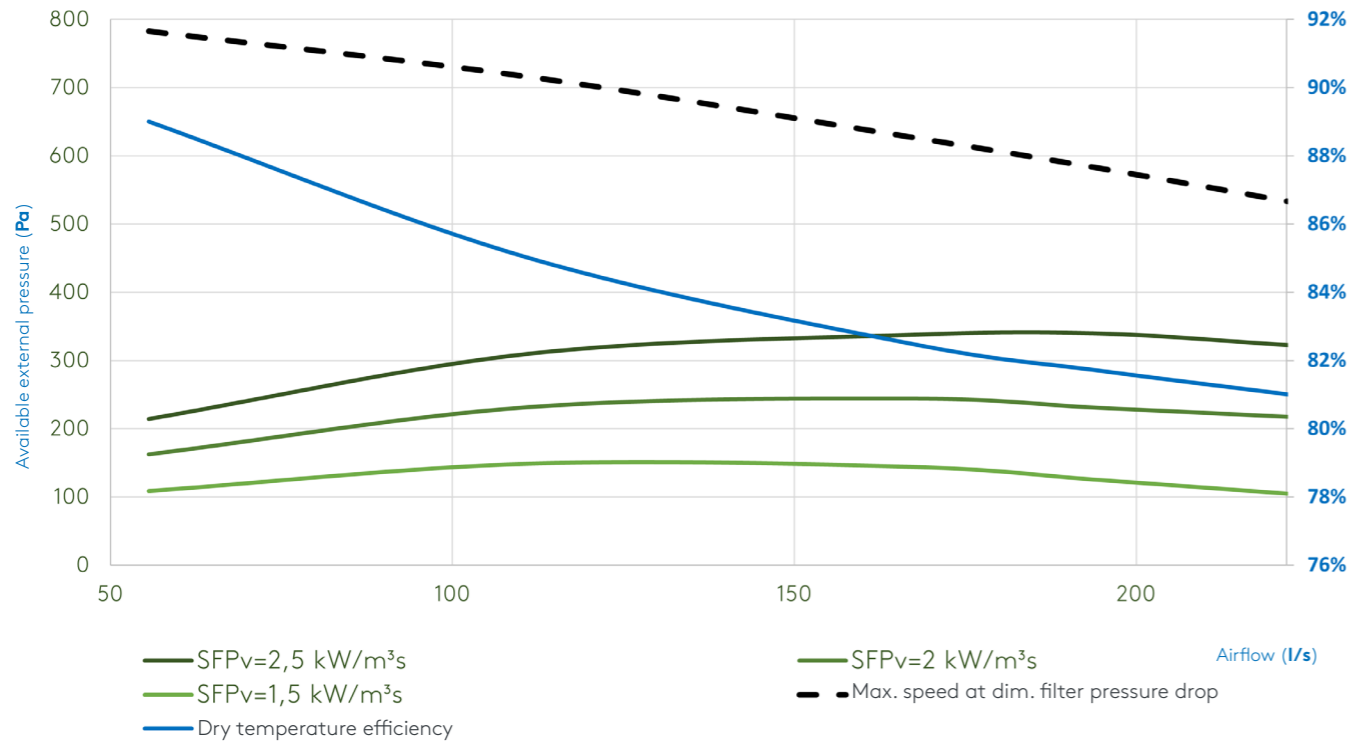

• AIRFLOW	200-800 m³/h
	56-222 l/s
• DIMENSIONS (L x W x H)	1465 x 1680 x 610
• WEIGHT	330 kg
• ELECTRIC POWER SUPPLY	1 x 230 V
• MAX. POWER CONSUMPTION	5.3 A
• RECOMMENDED FUSE PROTECTION	D6A - 10kA - AC3
• FILTER CLASS (BAG FILTER)	F7 (ePM1 70%) / M5 (ePM10 55%)
• CIRCULAR DUCT CONNECTIONS	Ø 315
• STANDARD DUCT CONNECTIONS (15 mm)	NOT APPLICABLE
• GUIDE DUCT CONNECTIONS (20 mm)	NOT APPLICABLE
• AMBIENT TEMPERATURE	-20 ... +50°C
• EN1886 CLASSIFICATION	T3/TB2/F9/L2/D2

AIRFLOW	Pa ext	SFPv	Speed dim. used/Max, supply air	Speed dim. used/Max, extract air	POWER CONSUMPTION	Dry temperature efficiency	Conditions
m³/h	l/s	kW/m³s	%	%	kW	%	
200	56	2,3	54	54	0,1	89%	
400	111	1,8	61	61	0,2	85%	
600	167	1,8	69	69	0,3	83%	
700	195	1,9	73	74	0,4	82%	
800	222	1,9	78	79	0,4	81%	

1. Calculated values at 200 Pa ext. pressure (150/50 Pa)
2. All data applies to fans with composite fan impeller
3. SFP and absorbed power calculated with clean filter
4. Speed dim. calculated at dim. filter pressure drop

DIMENSIONS (mm)

GLOBAL PX 04

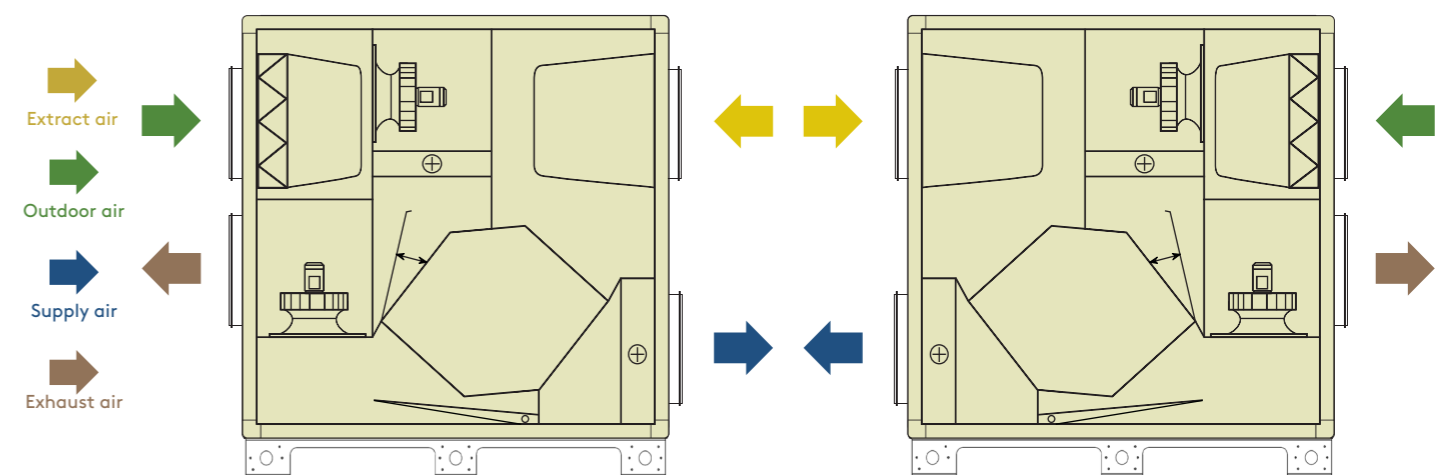
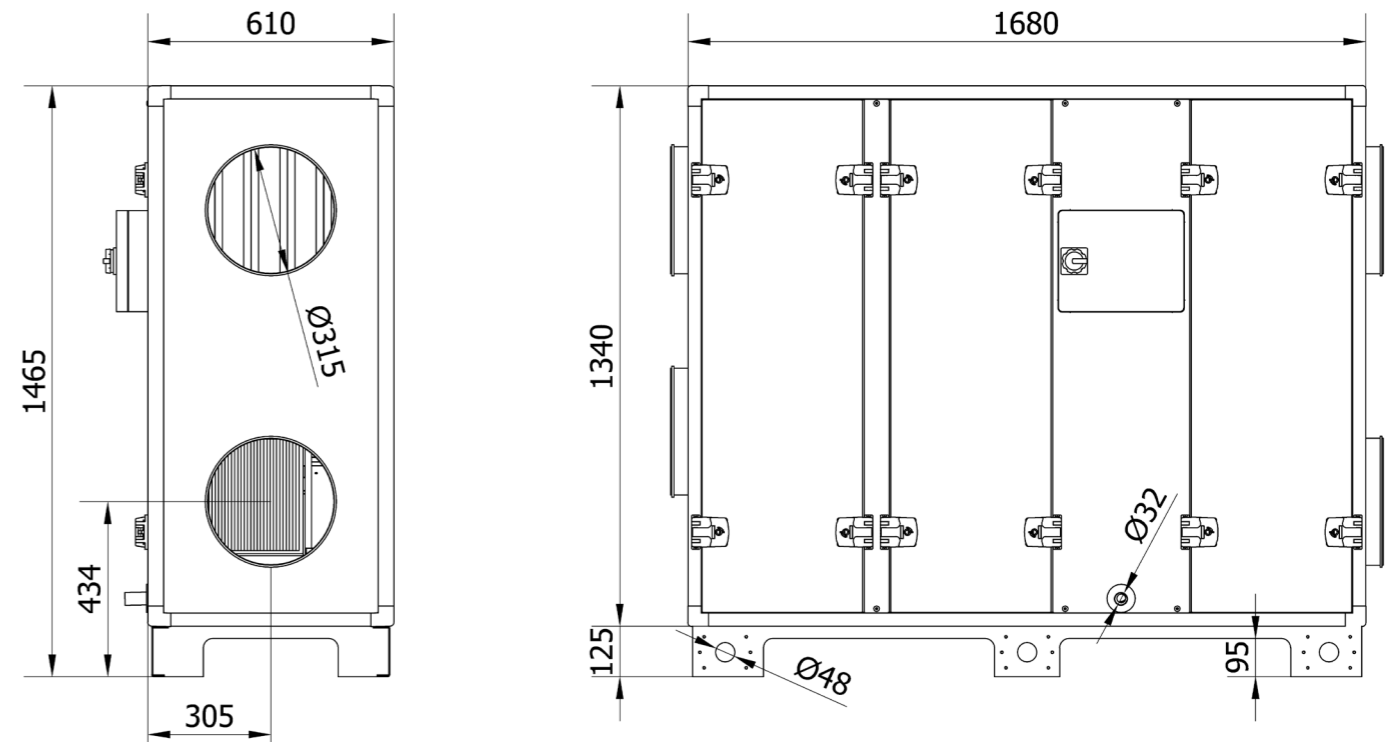

Right connection version

Left connection version

GLOBAL PX 05

FAN DIAGRAMS

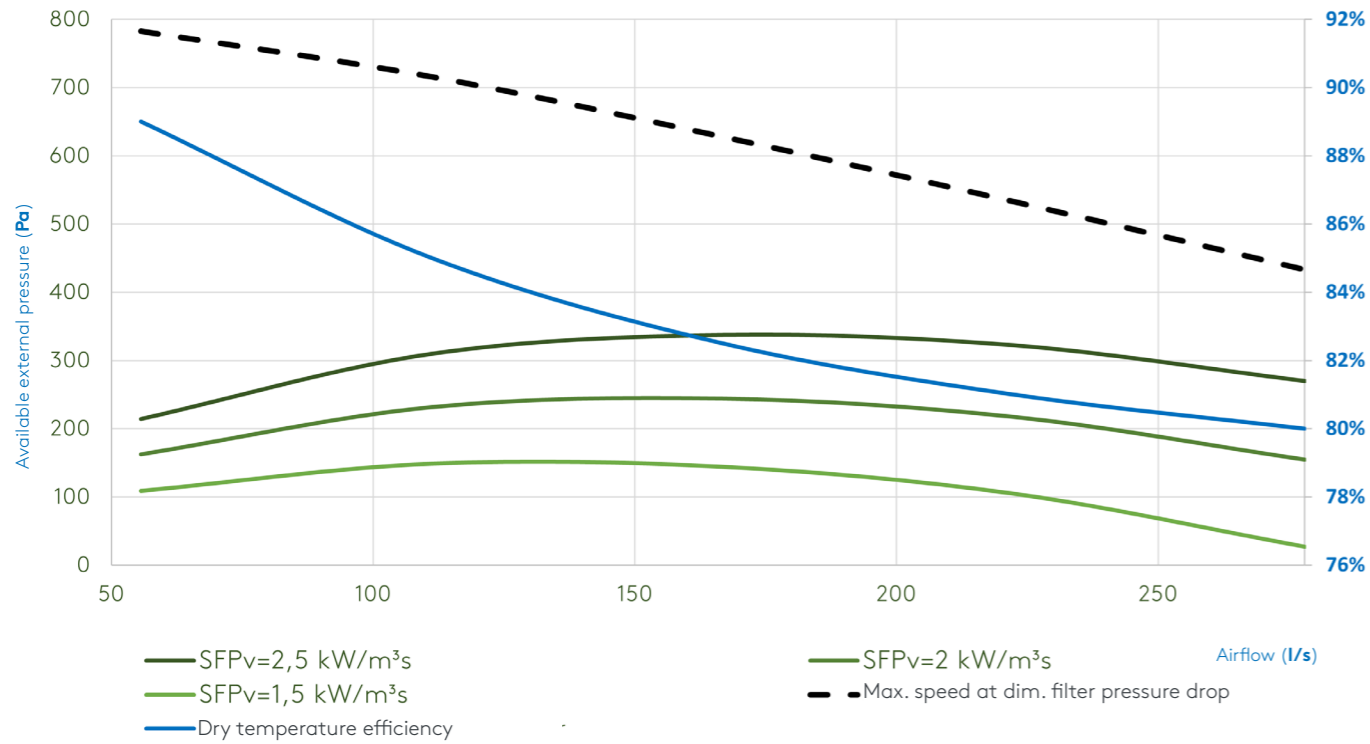

• AIRFLOW	200-1000 m³/h
	56-278 l/s
• DIMENSIONS (L x W x H)	1465 x 1680 x 610
• WEIGHT	330 kg
• ELECTRIC POWER SUPPLY	1 x 230 V
• MAX. POWER CONSUMPTION	5.3 A
• RECOMMENDED FUSE PROTECTION	D6A - 10kA - AC3
• FILTER CLASS (BAG FILTER)	F7 (ePM1 70%) / M5 (ePM10 55%)
• CIRCULAR DUCT CONNECTIONS	Ø 315
• STANDARD DUCT CONNECTIONS (15 mm)	NOT APPLICABLE
• GUIDE DUCT CONNECTIONS (20 mm)	NOT APPLICABLE
• AMBIENT TEMPERATURE	-20 ... +50°C
• EN1886 CLASSIFICATION	T3/TB2/F9/L2/D2

AIRFLOW	Pa ext	SFPv	Speed dim. used/Max, supply air	Speed dim. used/Max, extract air	POWER CONSUMPTION	Dry temperature efficiency	Conditions
m³/h	l/s	kW/m³/s	%	%	kW	%	
200	56	2,3	54	54	0,1	89%	
400	111	1,8	61	61	0,2	85%	
600	167	1,8	69	69	0,3	83%	
800	222	1,9	78	79	0,4	81%	
1000	278	2,2	87	89	0,6	80%	

1. Calculated values at 200 Pa ext. pressure (150/50 Pa)
2. All data applies to fans with composite fan impeller
3. SFP and absorbed power calculated with clean filter
4. Speed dim. calculated at dim. filter pressure drop

DIMENSIONS (mm)

GLOBAL PX 05

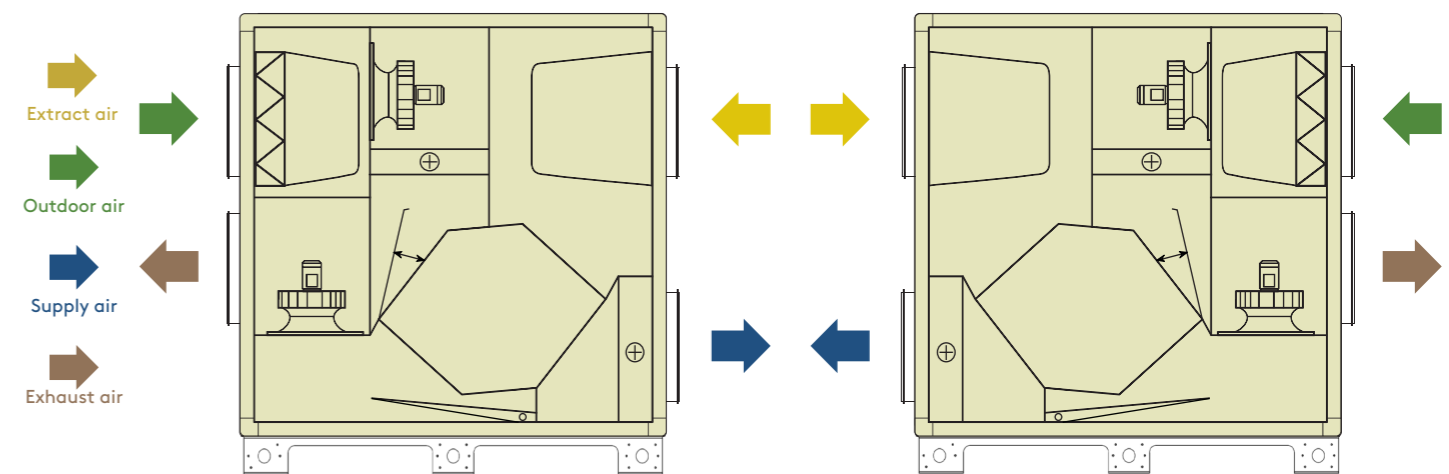
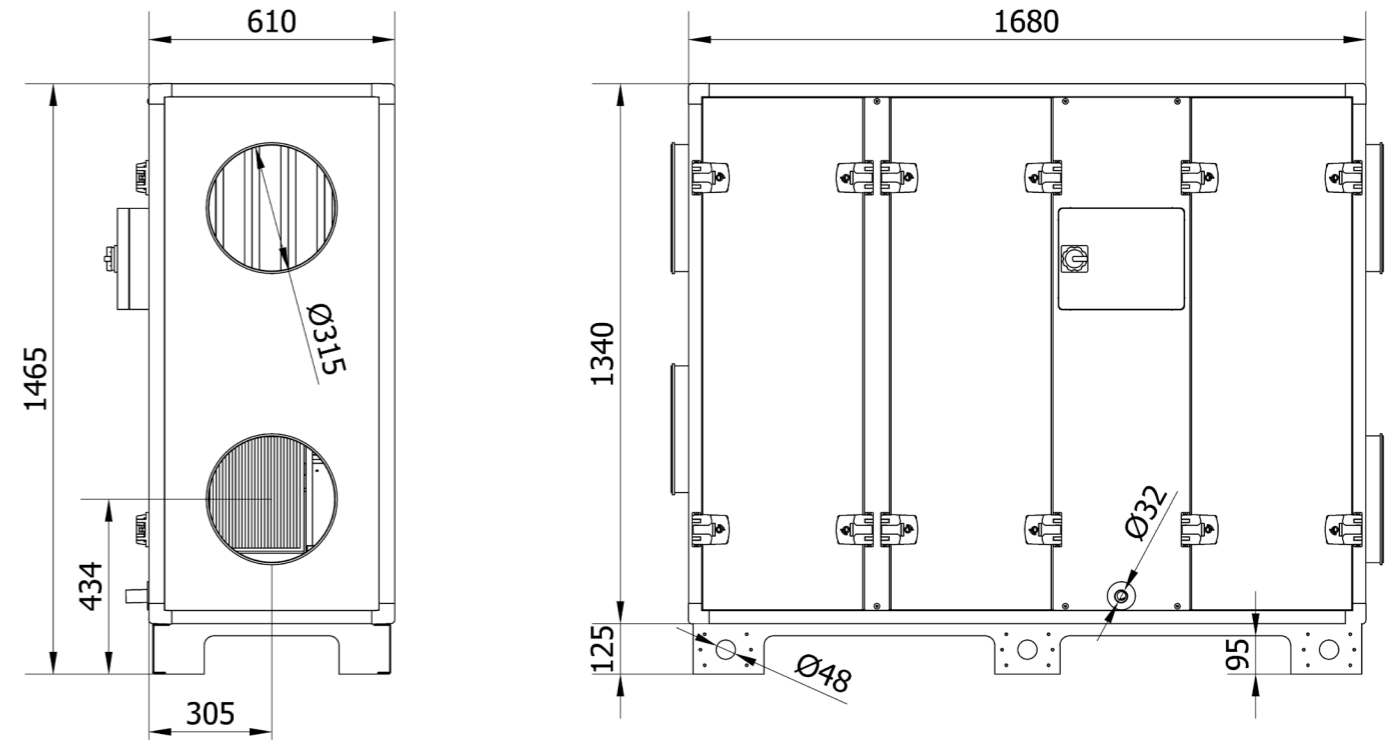

Right connection version

Left connection version

GLOBAL PX 06

FAN DIAGRAMS

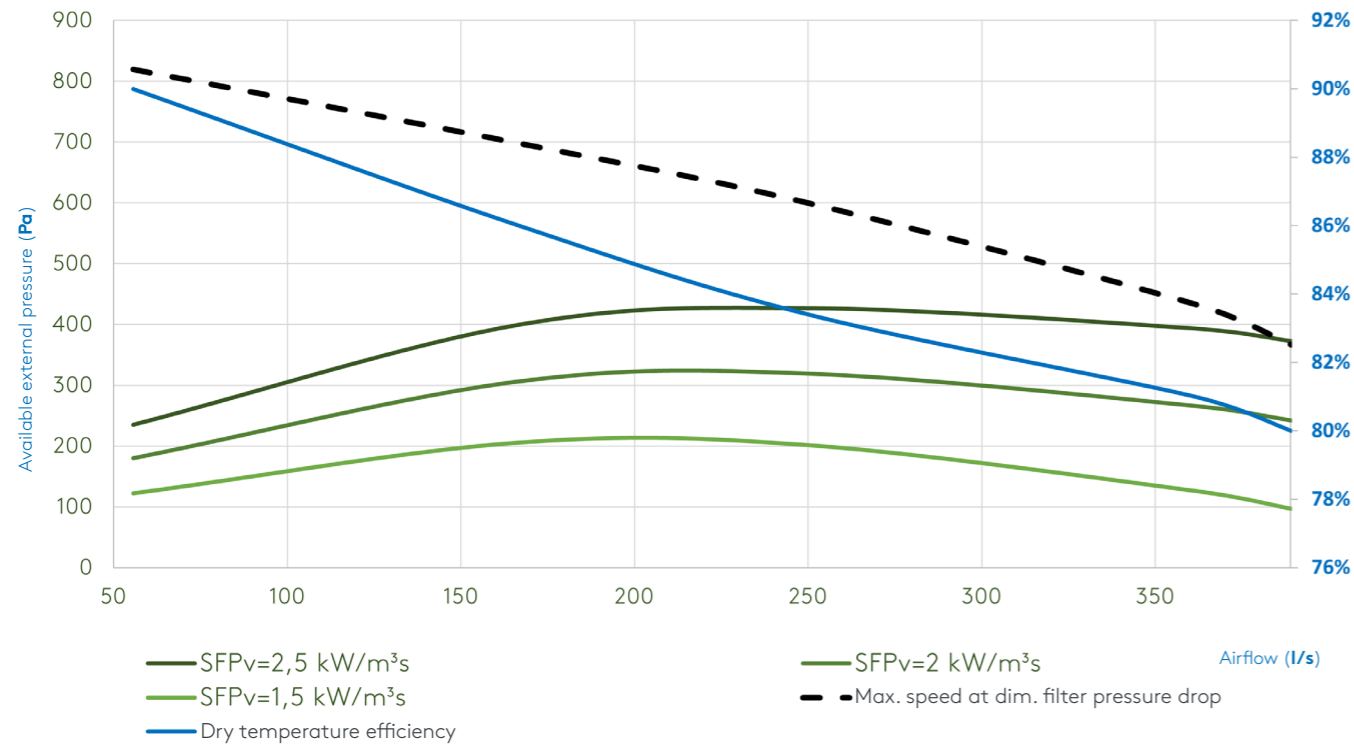

• AIRFLOW	200-1400 m³/h
	56-389 l/s
• DIMENSIONS (L x W x H)	1465 x 1680 x 815
• WEIGHT	330 kg
• ELECTRIC POWER SUPPLY	1 x 230 V
• MAX. POWER CONSUMPTION	5.3 A
• RECOMMENDED FUSE PROTECTION	D6A - 10kA - AC3
• FILTER CLASS (BAG FILTER)	F7 (ePM1 70%) / M5 (ePM10 55%)
• CIRCULAR DUCT CONNECTIONS	Ø 400
• STANDARD DUCT CONNECTIONS (15 mm)	NOT APPLICABLE
• GUIDE DUCT CONNECTIONS (20 mm)	NOT APPLICABLE
• AMBIENT TEMPERATURE	-20°C ... +50°C
• EN1886 CLASSIFICATION	T3/TB2/F9/L2/D2

AIRFLOW	Pa ext	SFPv	Speed dim. used/Max, supply air	Speed dim. used/Max, extract air	POWER CONSUMPTION	Dry temperature efficiency	Conditions
m³/h	l/s	kW/m³/s	%	%	kW	%	
200	56	2,1	52	52	0,1	90%	1. Calculated values at 200 Pa ext. pressure (150/50 Pa)
600	167	1,5	63	62	0,2	86%	2. All data applies to fans with composite fan impeller
900	250	1,5	73	72	0,4	83%	3. SFP and absorbed power calculated with clean filter
1300	361	1,8	86	87	0,6	81%	4. Speed dim. calculated at dim. filter pressure drop
1400	389	1,9	90	90	0,7	80%	

DIMENSIONS (mm)

GLOBAL PX 06

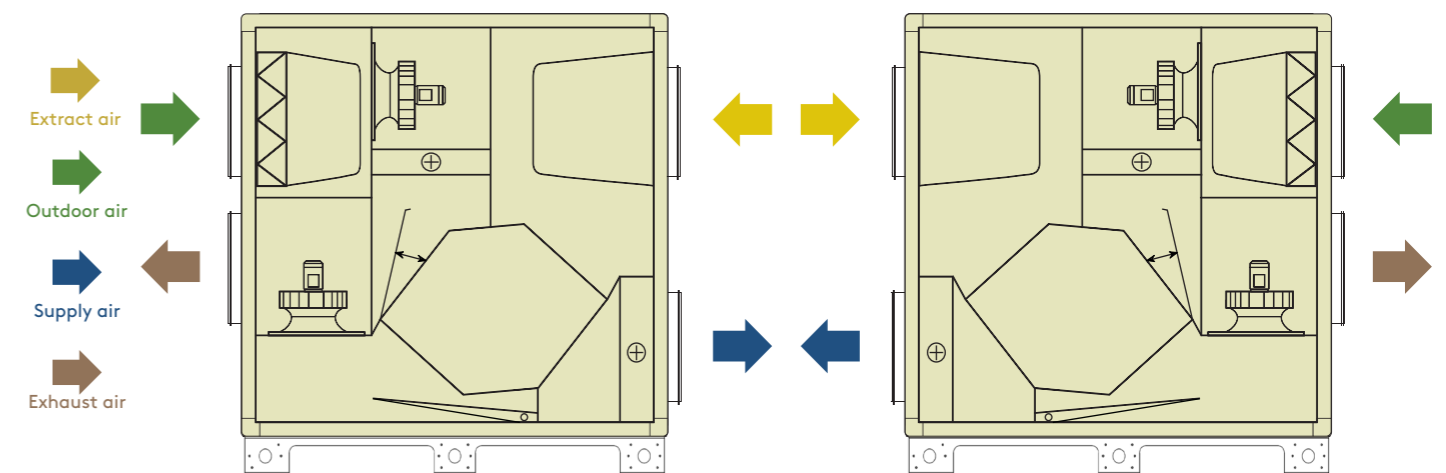
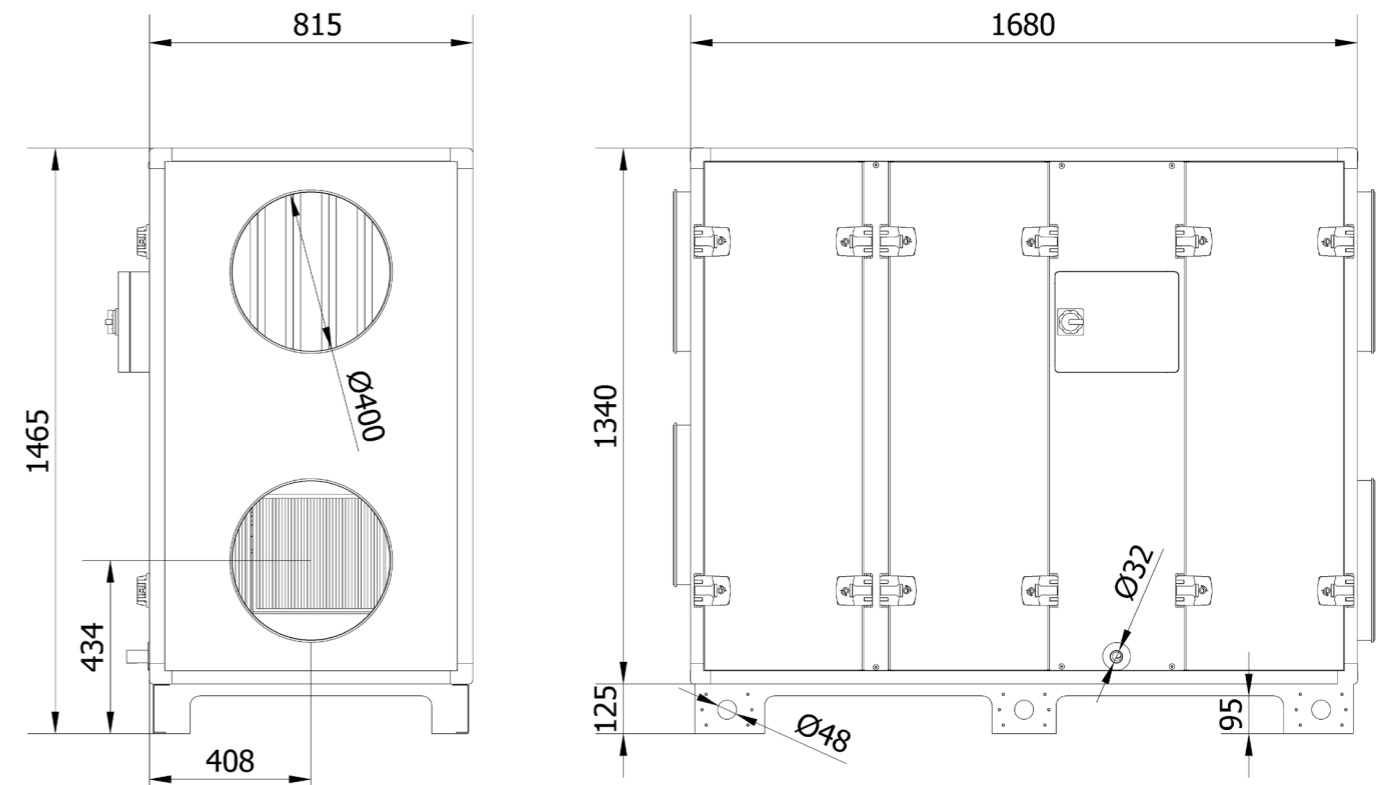

Right connection version

Left connection version

GLOBAL PX 08

FAN DIAGRAMS

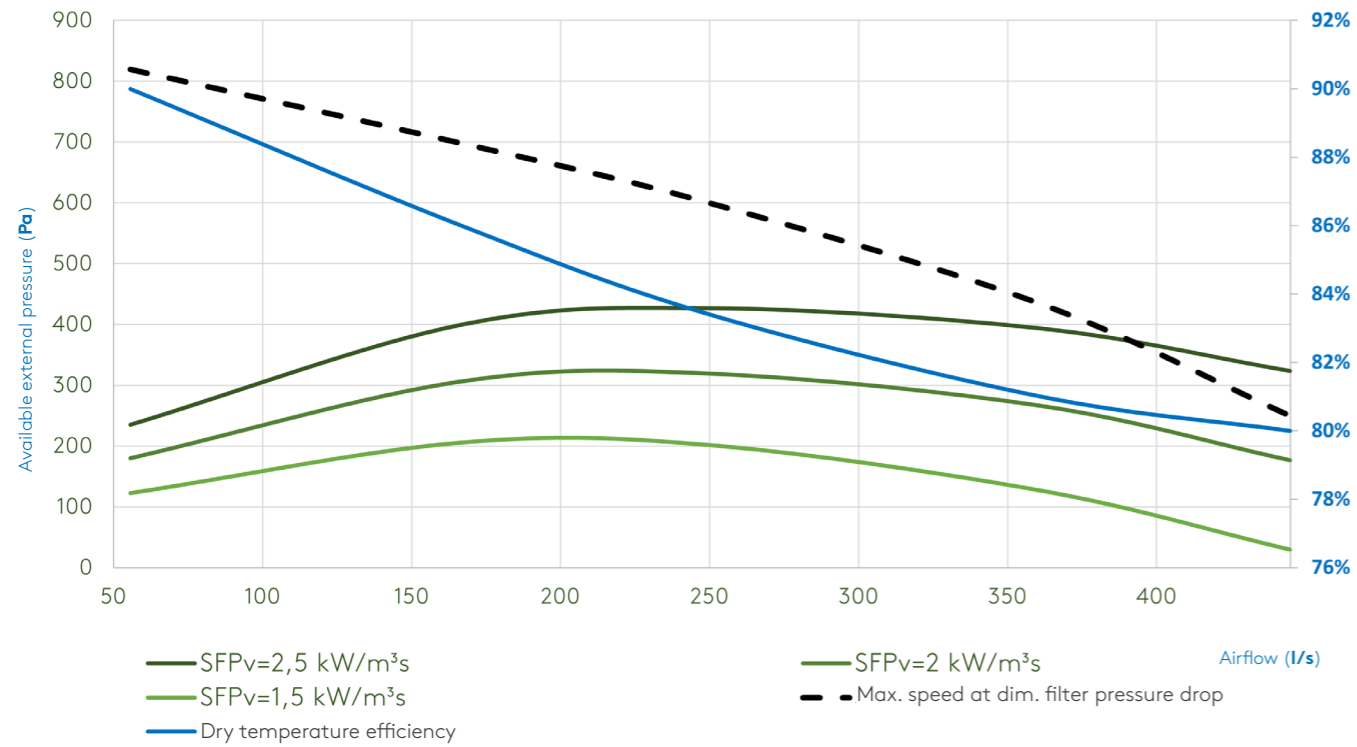

• AIRFLOW	200-1600 m³/h
	56-445 l/s
• DIMENSIONS (L x W x H)	145 x 1680 x 815
• WEIGHT	330 kg
• ELECTRIC POWER SUPPLY	1 x 230 V
• MAX. POWER CONSUMPTION	5.3 A
• RECOMMENDED FUSE PROTECTION	D6A - 10kA - AC3
• FILTER CLASS (BAG FILTER)	F7 (ePM1 70%) / M5 (ePM10 55%)
• CIRCULAR DUCT CONNECTIONS	Ø 400
• STANDARD DUCT CONNECTIONS (15 mm)	NOT APPLICABLE
• GUIDE DUCT CONNECTIONS (20 mm)	NOT APPLICABLE
• AMBIENT TEMPERATURE	-20°C ... +50°C
• EN1886 CLASSIFICATION	T3/TB2/F9/L2/D2

AIRFLOW	Pa ext	SFPv	Speed dim. used/Max, supply air	Speed dim. used/Max, extract air	POWER CONSUMPTION	Dry temperature efficiency	Conditions
m³/h	l/s	kW/m³/s	%	%	kW	%	
200	56	2,1	52	52	0,1	90%	
600	167	1,5	63	62	0,2	86%	
900	250	1,5	73	72	0,4	83%	
1300	361	1,8	86	87	0,6	81%	
1600	445	2,1	97	99	0,9	80%	

1. Calculated values at 200 Pa ext. pressure (150/50 Pa)
2. All data applies to fans with composite fan impeller
3. SFP and absorbed power calculated with clean filter
4. Speed dim. calculated at dim. filter pressure drop

DIMENSIONS (mm)

GLOBAL PX 08

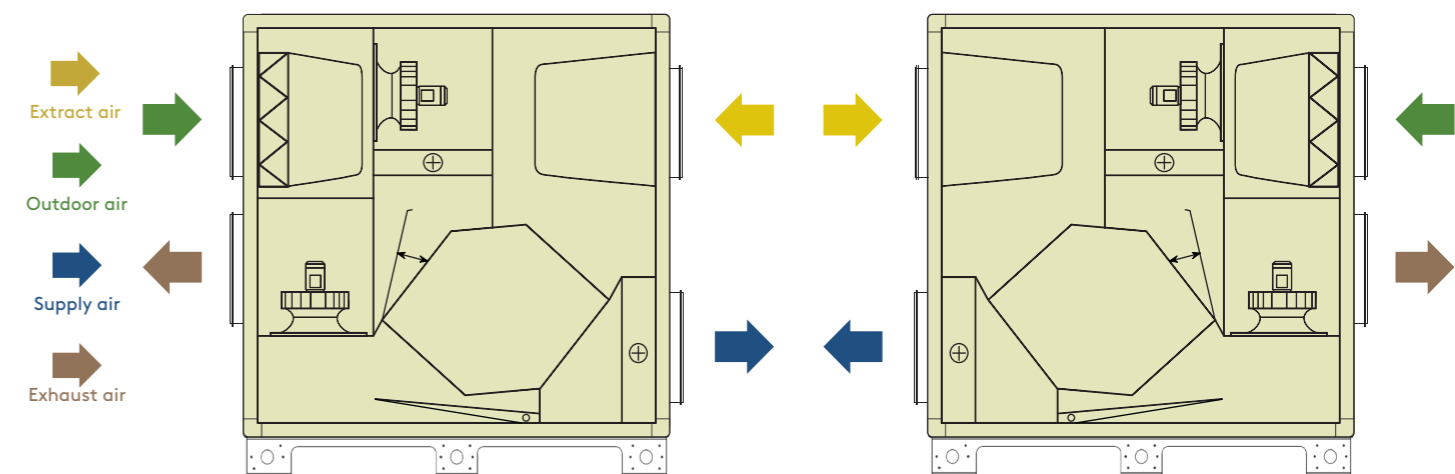
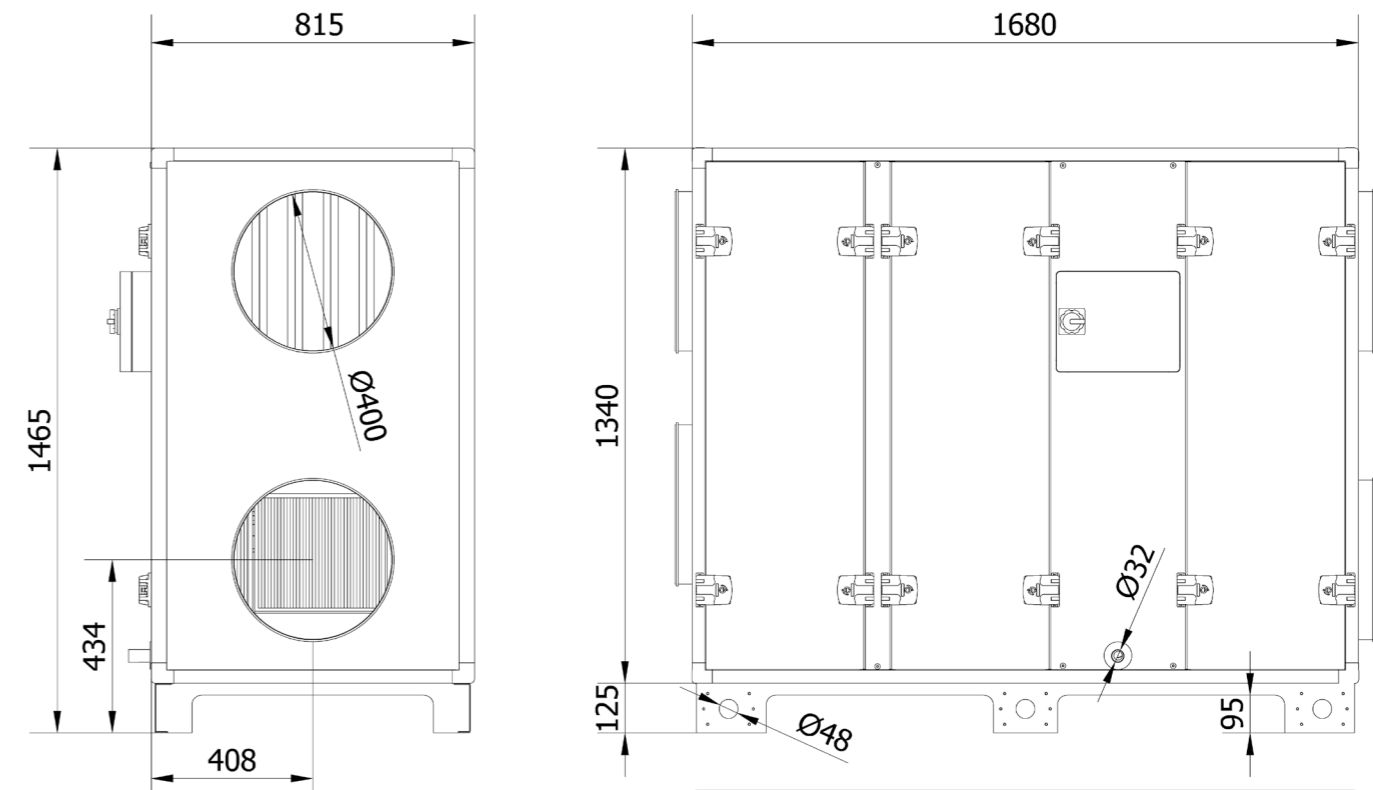

Right connection version

Left connection version

GLOBAL PX 12

FAN DIAGRAMS

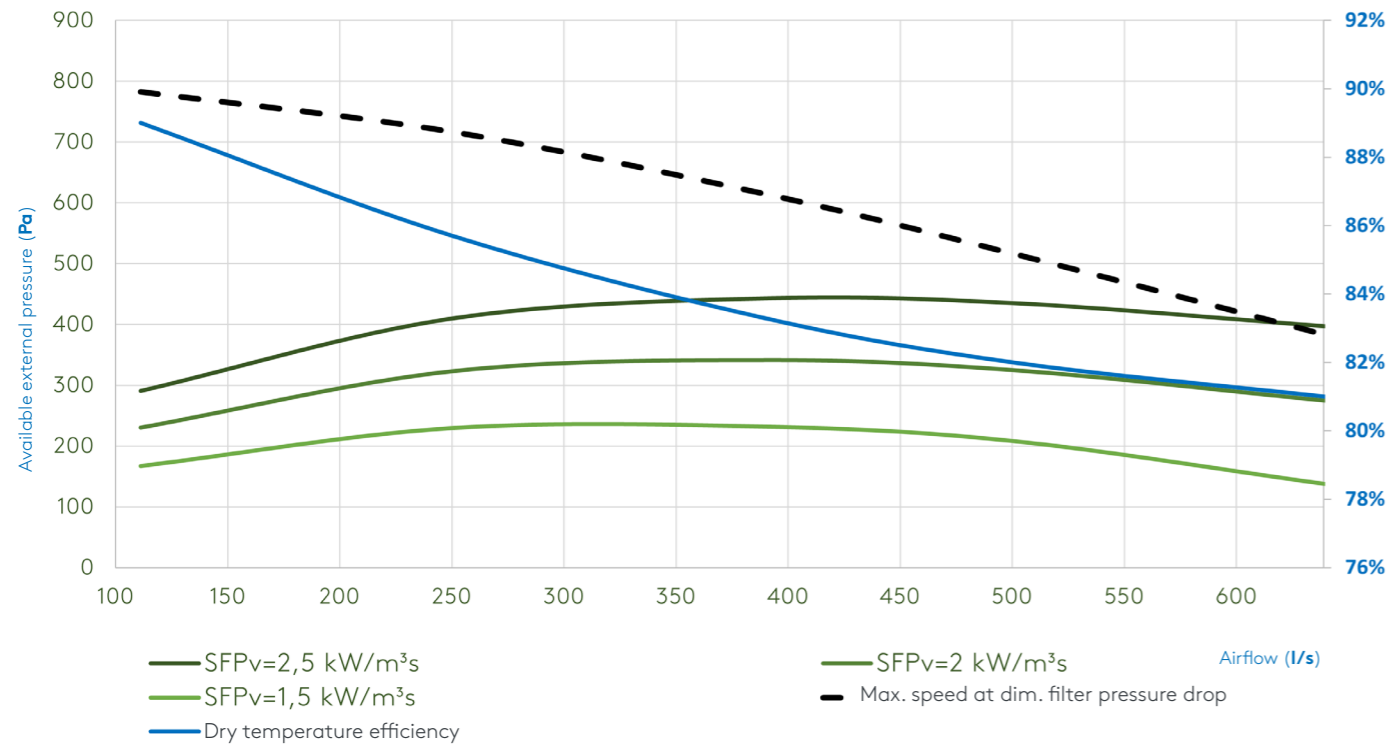

• AIRFLOW	400–2300 m³/h
	111–639 l/s
• DIMENSIONS (L x W x H)	1465 x 1680 x 1182
• WEIGHT	380 kg
• ELECTRIC POWER SUPPLY	1 x 230 V
• MAX. POWER CONSUMPTION	7.7 A
• RECOMMENDED FUSE PROTECTION	D10A - 10kA - AC3
• FILTER CLASS (BAG FILTER)	F7 (ePM1 70%) / M5 (ePM10 55%)
• CIRCULAR DUCT CONNECTIONS	Ø 400
• STANDARD DUCT CONNECTIONS (15 mm)	1069 x 547
• GUIDE DUCT CONNECTIONS (20 mm) (W x H)	1100 x 600
• AMBIENT TEMPERATURE	-20°C ... +50°C
• EN1886 CLASSIFICATION	T3/TB2/F9/L2/D2

AIRFLOW	Pa ext	SFPv	Speed dim. used/Max, supply air	Speed dim. used/Max, extract air	POWER CONSUMPTION	Dry temperature efficiency	Conditions
m³/h	l/s	kW/m³/s	%	%	kW	%	
400	111	200	1,7	54	53	0,2	89%
900	250	200	1,3	61	61	0,3	86%
1400	389	200	1,4	71	70	0,5	83%
1800	500	200	1,5	79	78	0,7	82%
2300	639	200	1,7	89	89	1,1	81%

1. Calculated values at 200 Pa ext. pressure (150/50 Pa)
 2. All data applies to fans with composite fan impeller
 3. SFP and absorbed power calculated with clean filter
 4. Speed dim. calculated at dim. filter pressure drop

DIMENSIONS (mm)

GLOBAL PX 12

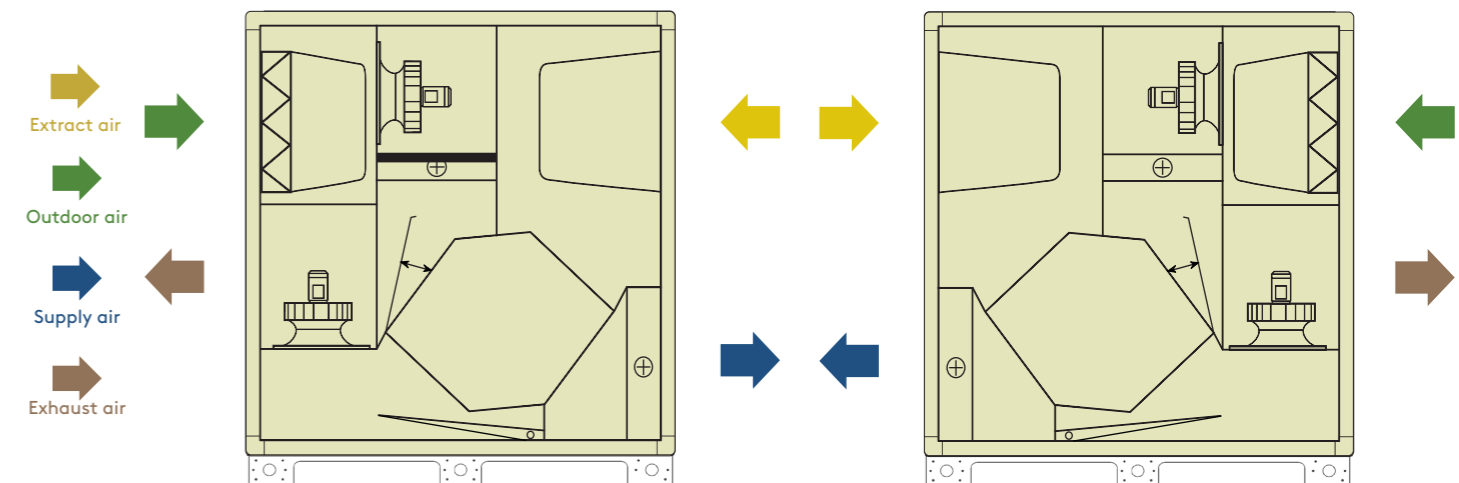
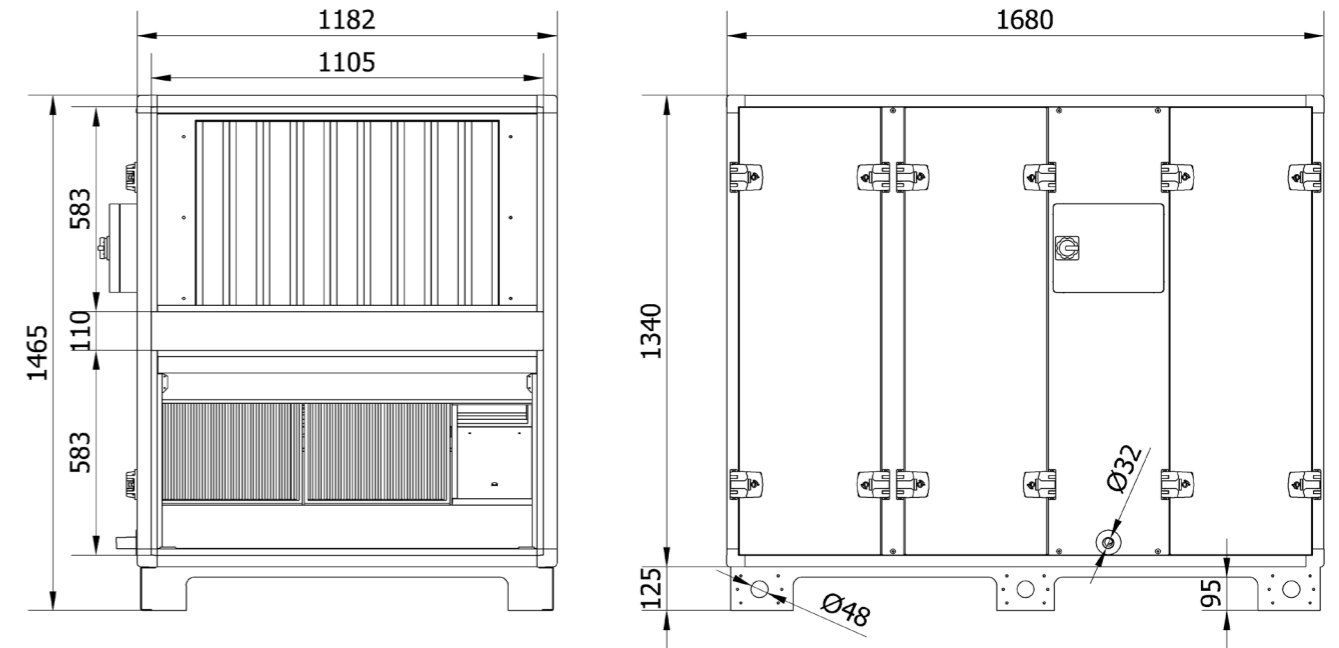

GLOBAL PX 13

FAN DIAGRAMS

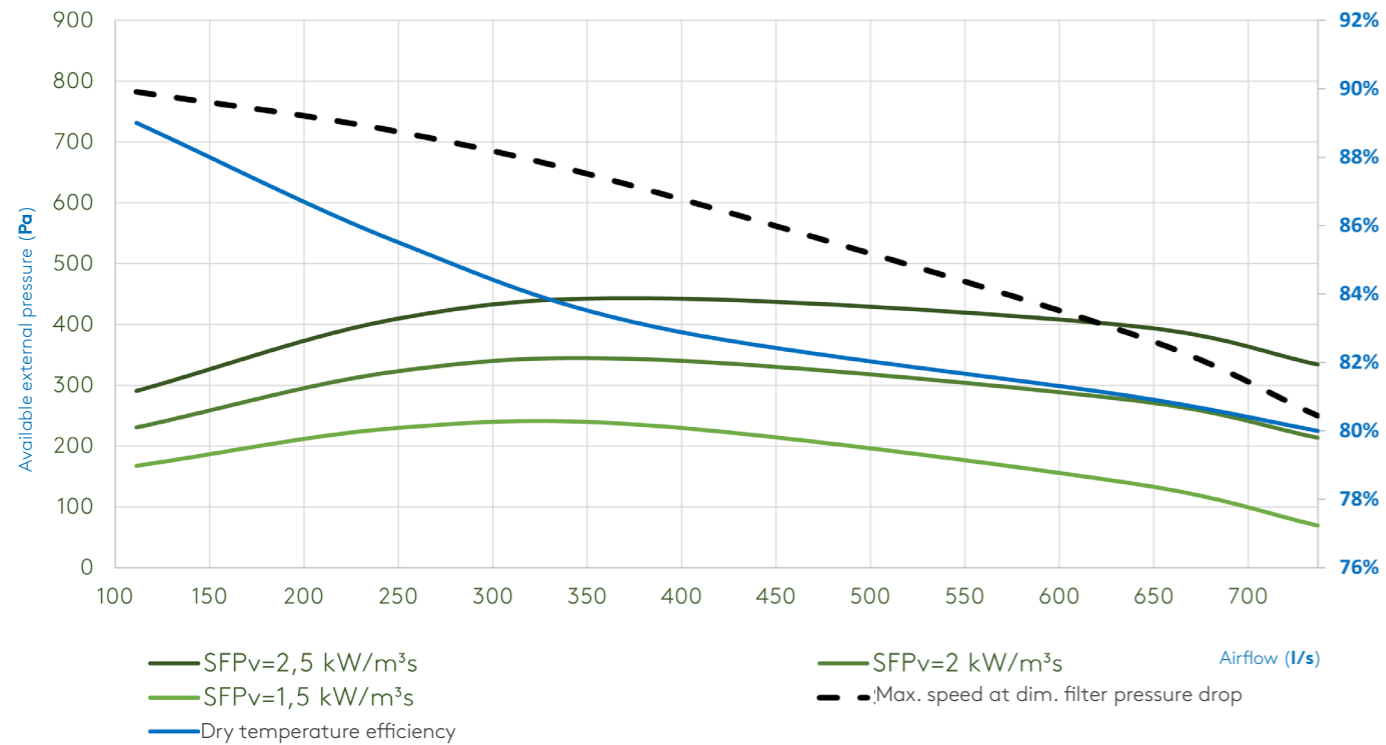

• AIRFLOW	400–2650 m³/h
	111–737 l/s
• DIMENSIONS (L x W x H)	1465 x 1680 x 1182
• WEIGHT	380 kg
• ELECTRIC POWER SUPPLY	1 x 230 V
• MAX. POWER CONSUMPTION	7.7 A
• RECOMMENDED FUSE PROTECTION	D10A - 10kA - AC3
• FILTER CLASS (BAG FILTER)	F7 (ePM1 70%) / M5 (ePM10 55%)
• CIRCULAR DUCT CONNECTIONS	Ø 400
• STANDARD DUCT CONNECTIONS (15 mm)	1069 x 547
• GUIDE DUCT CONNECTIONS (20 mm) (W x H)	1100 x 600
• AMBIENT TEMPERATURE	-20 ... +50°C
• EN1886 CLASSIFICATION	T3/TB2/F9/L2/D2

AIRFLOW	Pa ext	SFPv	Speed dim. used/Max, supply air	Speed dim. used/Max, extract air	POWER CONSUMPTION	Dry temperature efficiency	Conditions
m³/h	l/s	kW/m³/s	%	%	kW	%	
400	111	200	54	53	0,2	89%	1. Calculated values at 200 Pa ext. pressure (150/50 Pa) 2. All data applies to fans with composite fan impeller 3. SFP and absorbed power calculated with clean filter 4. Speed dim. calculated at dim. filter pressure drop
900	250	200	61	61	0,3	86%	
1400	389	200	71	70	0,5	83%	
2300	639	200	89	89	1,1	81%	
2650	737	200	97	97	1,4	80%	

DIMENSIONS (mm)

GLOBAL PX 13

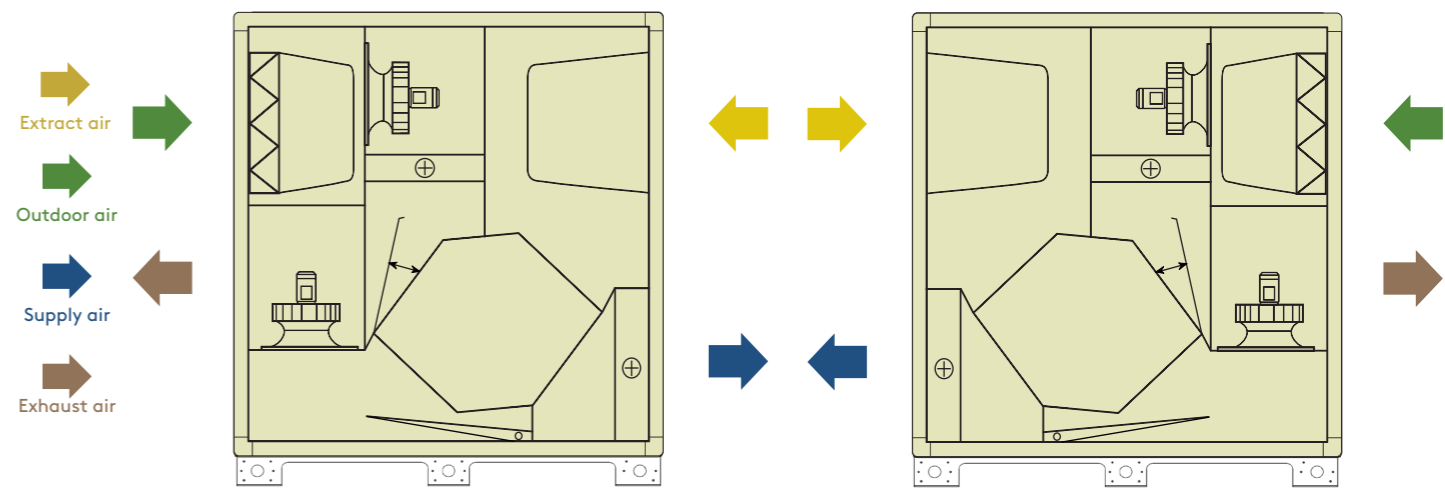
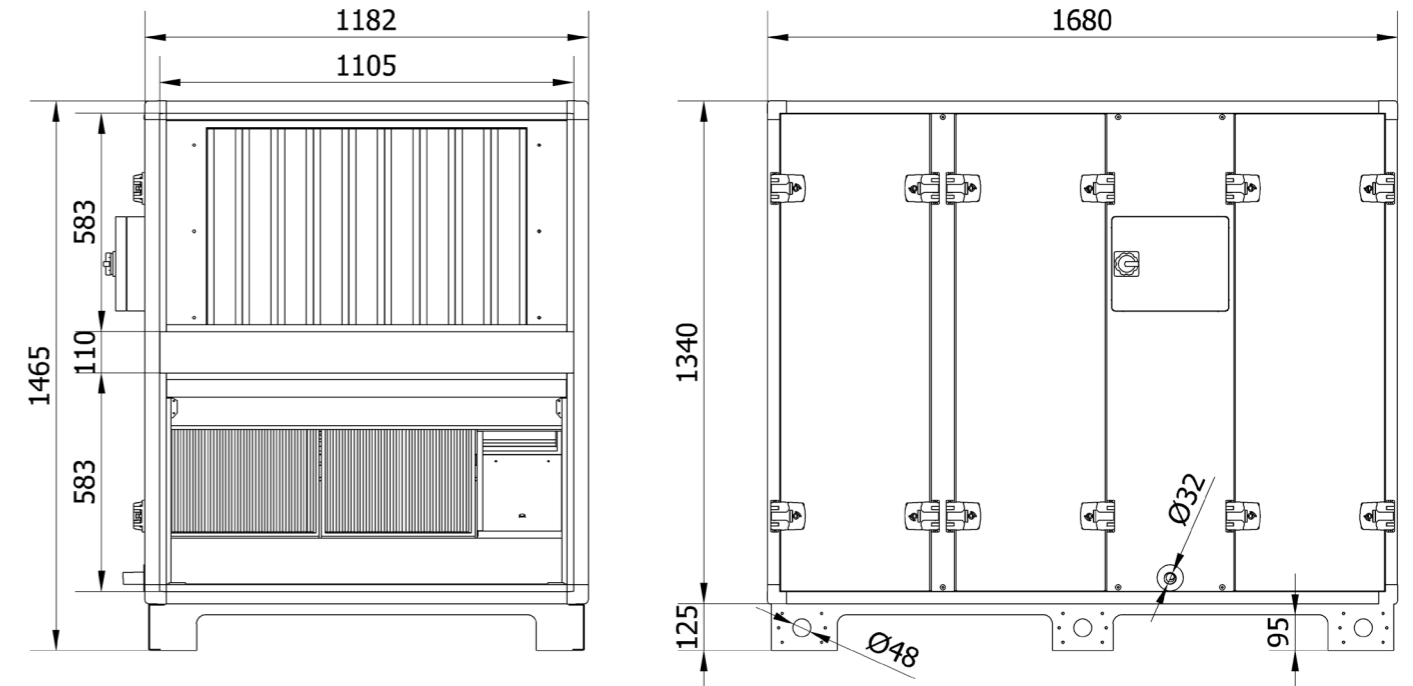

Right connection version

Left connection version

GLOBAL PX 16

FAN DIAGRAMS

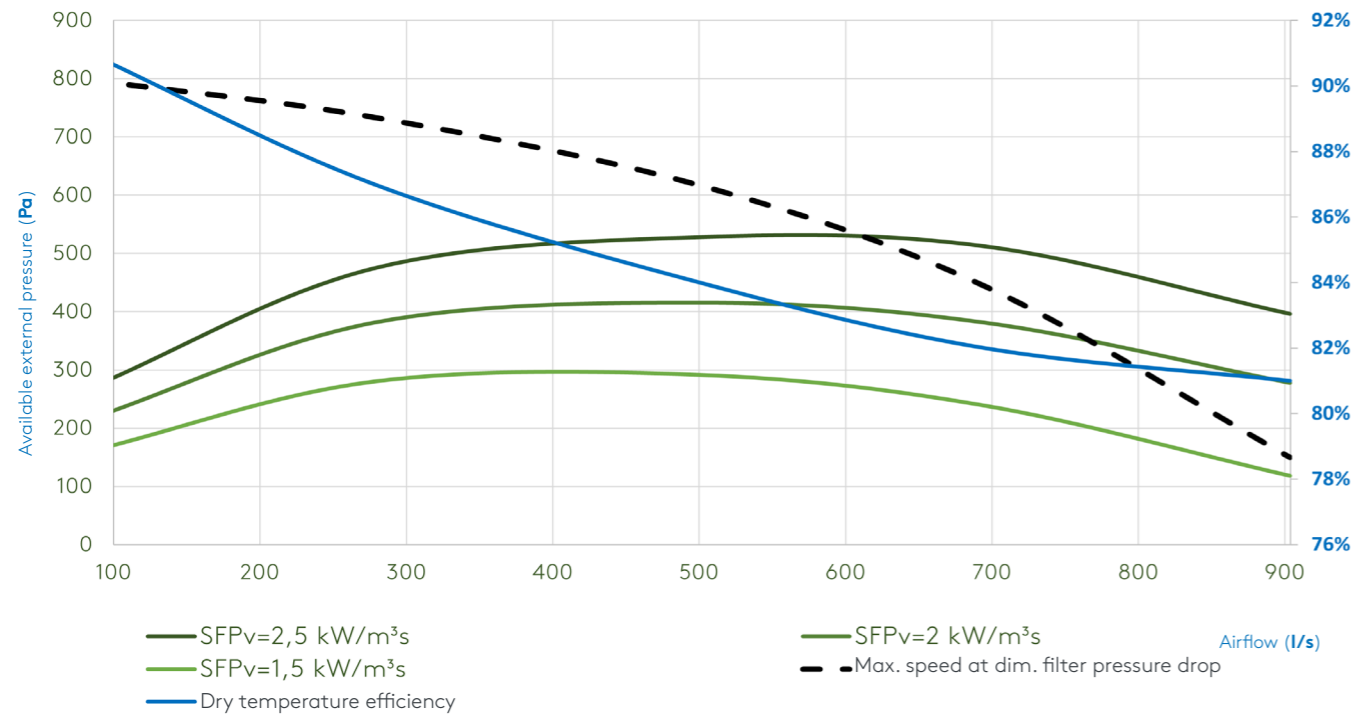

• AIRFLOW	300-3250 m³/h
	83-904 l/s
• DIMENSIONS (L x W x H)	1465 x 1680 x 1640
• WEIGHT	490 kg
• ELECTRIC POWER SUPPLY	1 x 230 V
• MAX. POWER CONSUMPTION	7.7 A
• RECOMMENDED FUSE PROTECTION	D10A - 10kA - AC3
• FILTER CLASS (BAG FILTER)	F7 (ePM1 70%) / M5 (ePM10 55%)
• CIRCULAR DUCT CONNECTIONS	NOT APPLICABLE
• STANDARD DUCT CONNECTIONS (15 mm)	1105 x 583
• GUIDE DUCT CONNECTIONS (20 mm) (W x H)	1600 x 600
• AMBIENT TEMPERATURE	-20°C ... +50°C
• EN1886 CLASSIFICATION	T3/TB2/F9/L2/D2

AIRFLOW	Pa ext	SFPv	Speed dim. used/Max, supply air	Speed dim. used/Max, extract air	POWER CONSUMPTION	Dry temperature efficiency	Conditions
m³/h	l/s	kW/m³s	%	%	kW	%	
300	83	200	1,8	51	0,2	91%	
1000	278	200	1,1	59	0,3	87%	
1800	500	200	1,2	72	0,6	84%	
2500	695	200	1,4	86	1,0	82%	
3250	904	200	1,7	102	1,6	81%	

1. Calculated values at 200 Pa ext. pressure (150/50 Pa)
2. All data applies to fans with composite fan impeller
3. SFP and absorbed power calculated with clean filter
4. Speed dim. calculated at dim. filter pressure drop

DIMENSIONS (mm)

GLOBAL PX 16

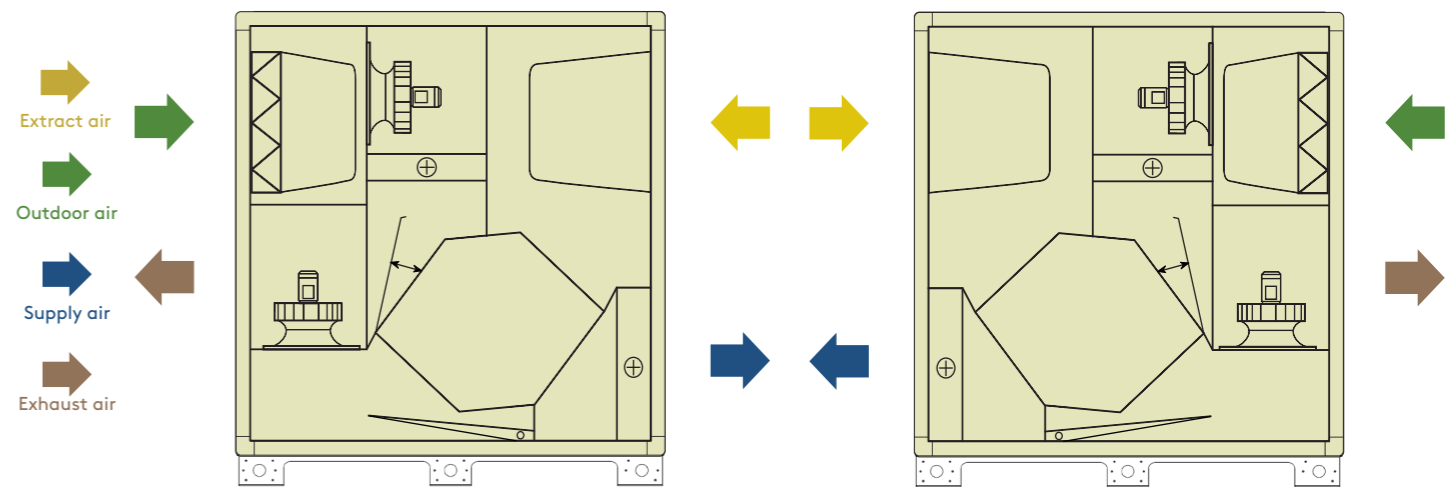
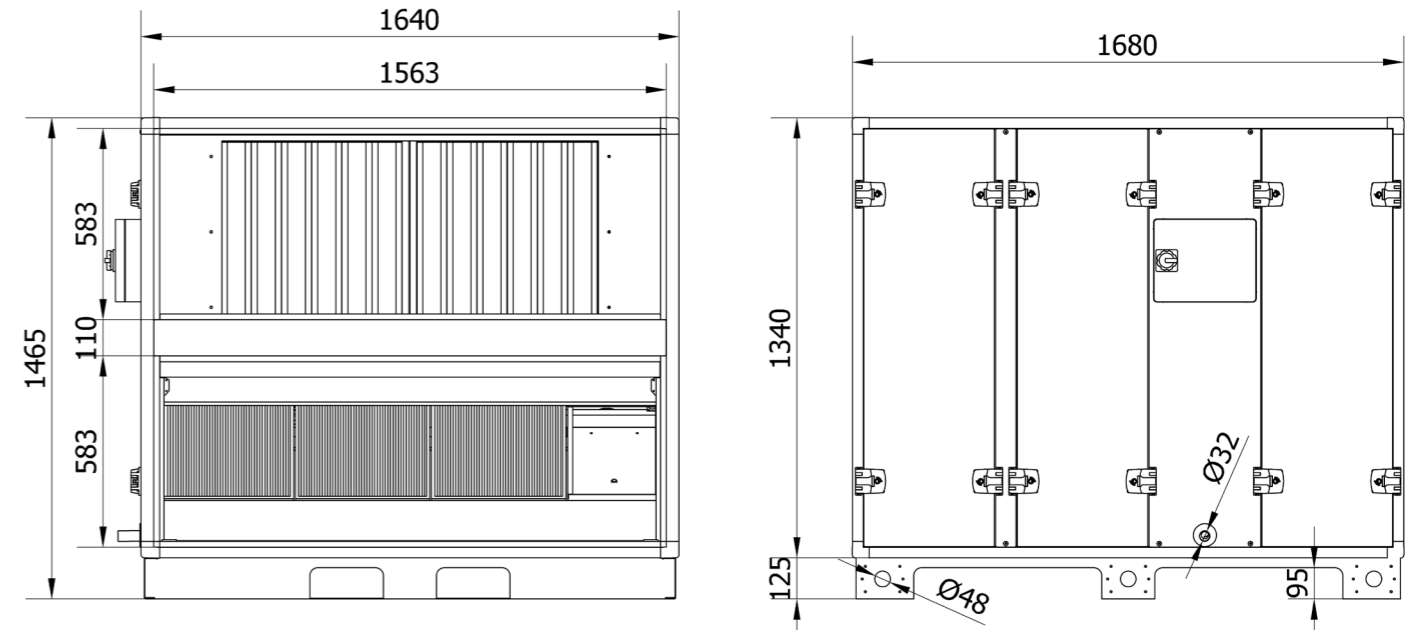

Right connection version

Left connection version

GLOBAL PX 18

FAN DIAGRAMS

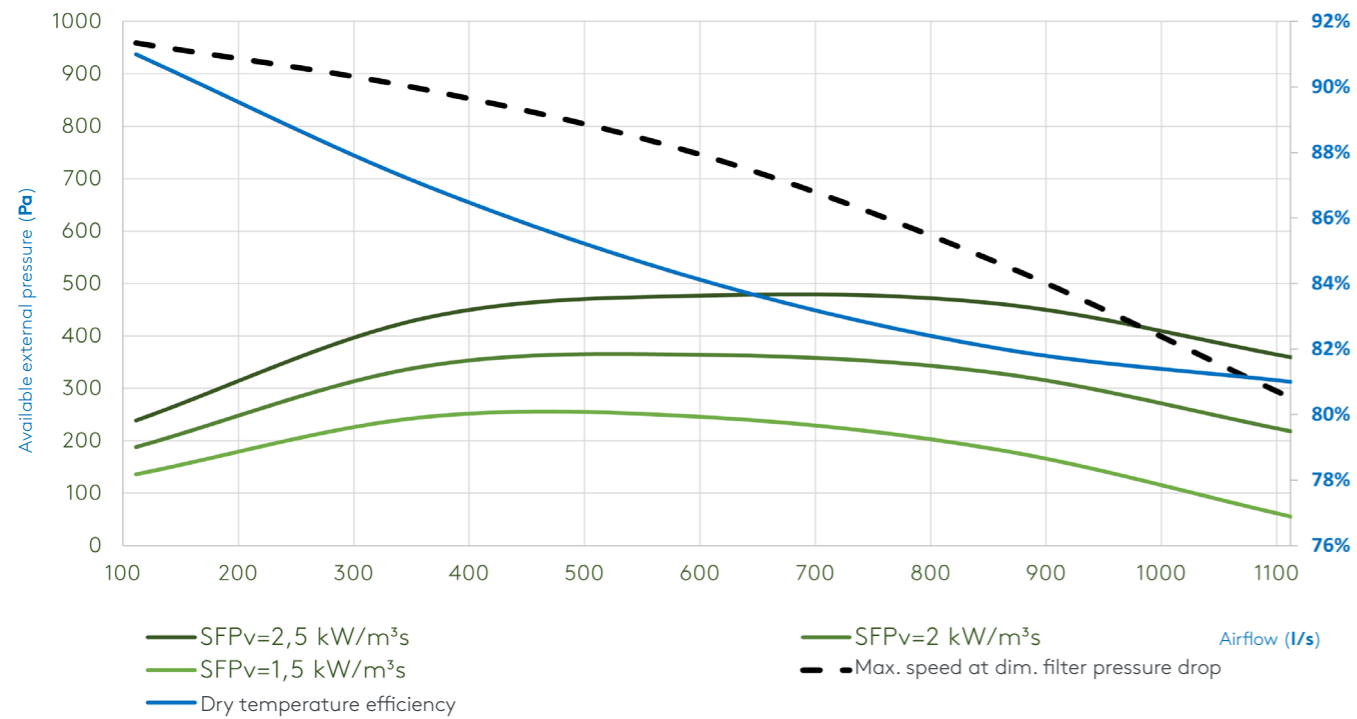

• AIRFLOW	400–4000 m³/h
	111–1112 l/s
• DIMENSIONS (L x W x H)	1465 x 1880 x 2015
• WEIGHT	720 kg
• ELECTRIC POWER SUPPLY	1 x 230 V
• MAX. POWER CONSUMPTION	12.7 A
• RECOMMENDED FUSE PROTECTION	D10A - 10kA - AC3
• FILTER CLASS (BAG FILTER)	F7 (ePM1 70%) / M5 (ePM10 55%)
• CIRCULAR DUCT CONNECTIONS	NOT APPLICABLE
• STANDARD DUCT CONNECTIONS (15 mm)	1105 x 583
• GUIDE DUCT CONNECTIONS (20 mm) (W x H)	2000 x 600
• AMBIENT TEMPERATURE	-20°C ... +50°C
• EN1886 CLASSIFICATION	T3/TB2/F9/L2/D2

AIRFLOW	Pa ext	SFPv	Speed dim. used/Max, supply air	Speed dim. used/Max, extract air	POWER CONSUMPTION	Dry temperature efficiency	Conditions
m³/h	l/s	kW/m³/s	%	%	kW	%	
400	111	2,1	47	46	0,2	91%	
1300	361	2,0	56	54	0,5	87%	
2200	612	2,0	68	65	0,8	84%	
3100	862	1,6	82	78	1,3	82%	
4000	1112	1,9	96	92	2,2	81%	

1. Calculated values at 200 Pa ext. pressure (150/50 Pa)
2. All data applies to fans with composite fan impeller
3. SFP and absorbed power calculated with clean filter
4. Speed dim. calculated at dim. filter pressure drop

DIMENSIONS (mm)

GLOBAL PX 18

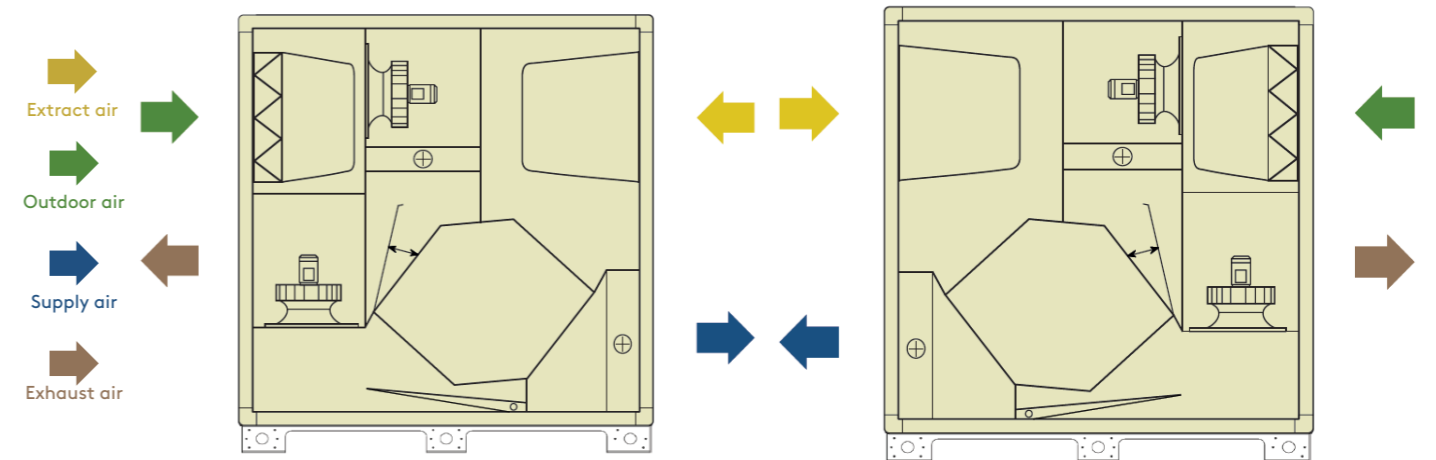
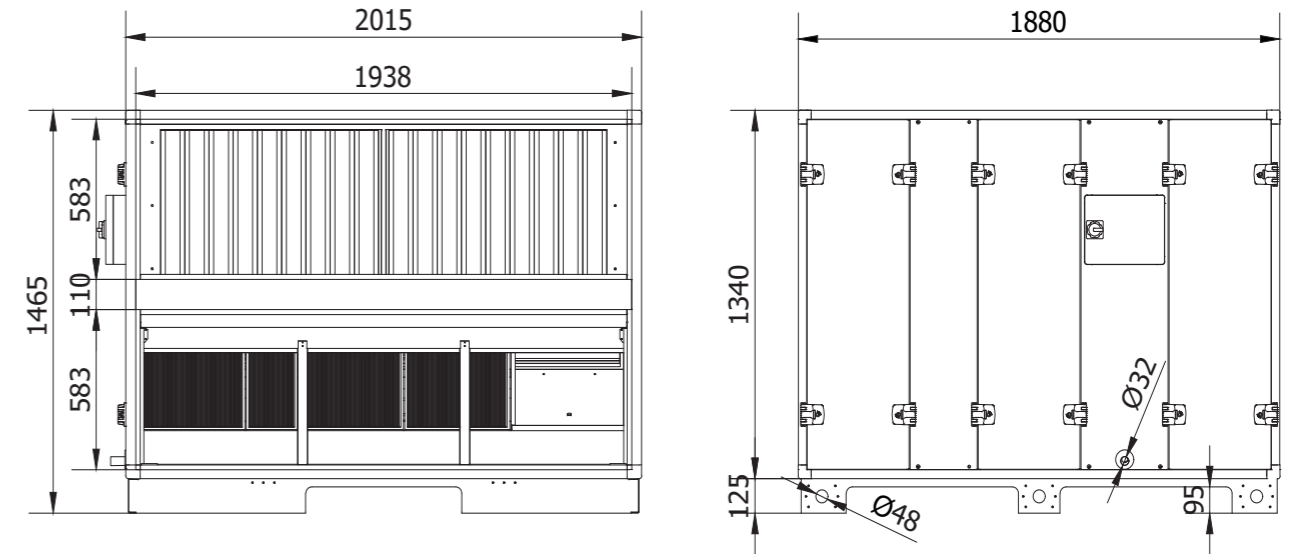

Right connection version

Left connection version

GLOBAL PX 20

FAN DIAGRAMS

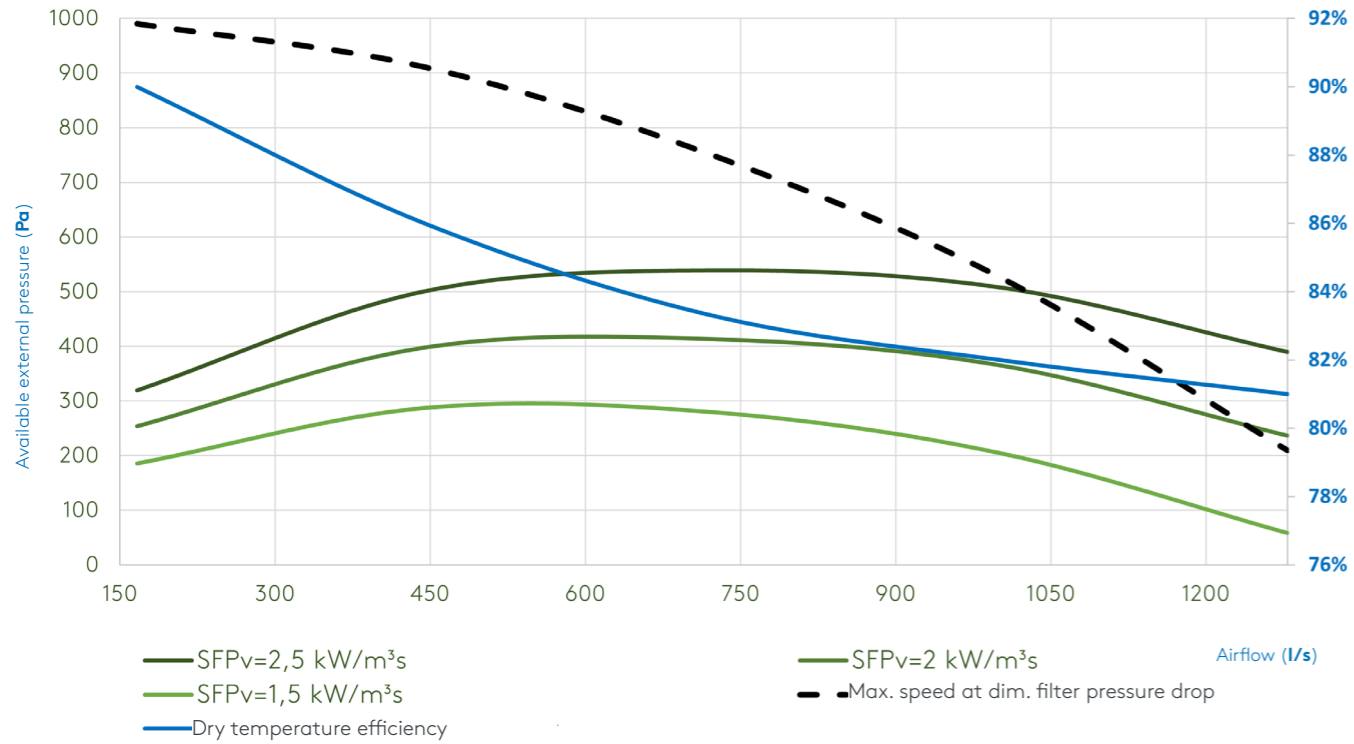

• AIRFLOW	600-4600 m³/h 167-1279 l/s
• DIMENSIONS (L x W x H)	1825 x 2557 x 1640
• WEIGHT	930 kg
• ELECTRIC POWER SUPPLY	1 x 230 V
• MAX. POWER CONSUMPTION	12.7 A
• RECOMMENDED FUSE PROTECTION	D10A - 10kA - AC3
• FILTER CLASS (BAG FILTER)	F7 (ePM1 70%) / M5 (ePM10 55%)
• CIRCULAR DUCT CONNECTIONS	NOT APPLICABLE
• STANDARD DUCT CONNECTIONS (15 mm)	1560 x 710
• GUIDE DUCT CONNECTIONS (20 mm) (W x H)	1600 x 700
• AMBIENT TEMPERATURE	-20°C ... +50°C
• EN1886 CLASSIFICATION	T3/TB2/F9/L2/D2

AIRFLOW	Pa ext	SFPv	Speed dim. used/Max, supply air	Speed dim. used/Max, extract air	POWER CONSUMPTION	Dry temperature efficiency	Conditions
m³/h	l/s	kW/m³/s	%	%	kW	%	
600	167	200	1,6	47	47	0,3	90%
1600	445	200	1,1	56	55	0,5	86%
2600	723	200	1,2	70	68	0,9	83%
3600	1001	200	1,5	84	82	1,5	82%
4600	1279	200	1,9	100	98	2,4	81%

1. Calculated values at 200 Pa ext. pressure (150/50 Pa)
2. All data applies to fans with composite fan impeller
3. SFP and absorbed power calculated with clean filter
4. Speed dim. calculated at dim. filter pressure drop

DIMENSIONS (mm)

GLOBAL PX 20

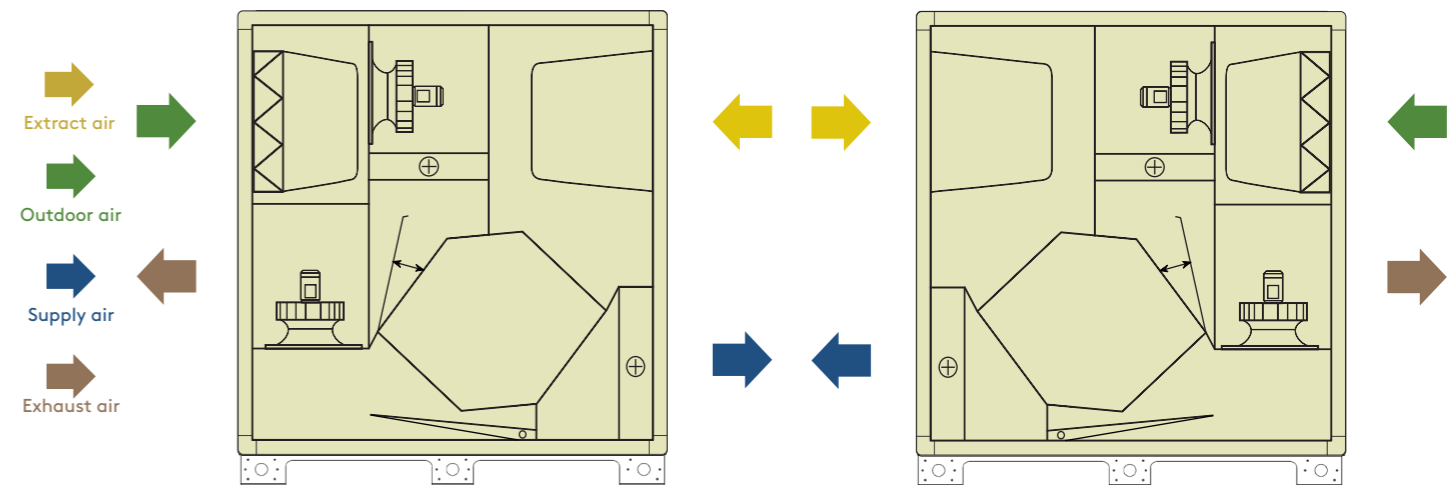
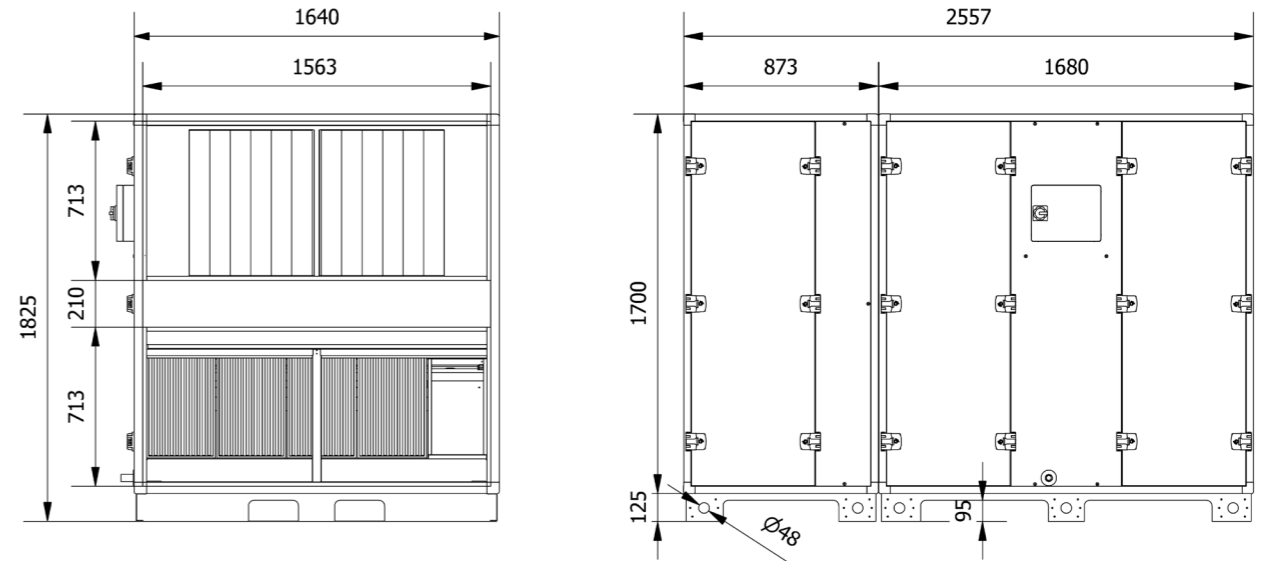

Right connection version

Left connection version

GLOBAL PX 24

FAN DIAGRAMS

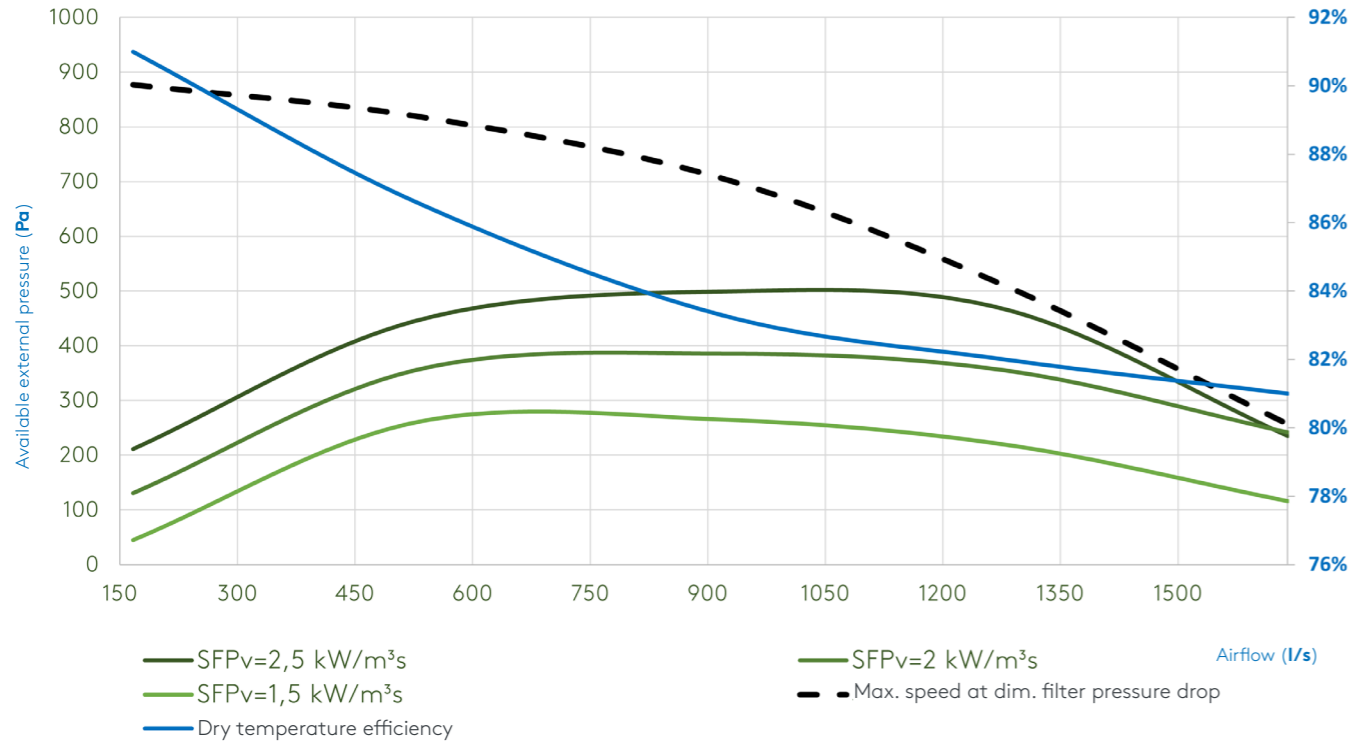

• AIRFLOW	600-5900 m³/h
	167-1640 l/s
• DIMENSIONS (L x W x H)	1825 x 2557 x 2015
• WEIGHT	1120 kg
• ELECTRIC POWER SUPPLY	3 x 400 V + N
• MAX. POWER CONSUMPTION	6.5 A
• RECOMMENDED FUSE PROTECTION	D10A - 10kA - AC3
• FILTER CLASS (BAG FILTER)	F7 (ePM1 70%) / M5 (ePM10 55%)
• CIRCULAR DUCT CONNECTIONS	NOT APPLICABLE
• STANDARD DUCT CONNECTIONS (15 mm)	1938 x 713
• GUIDE DUCT CONNECTIONS (20 mm) (W x H)	1900 x 700
• AMBIENT TEMPERATURE	-20°C ... +50°C
• EN1886 CLASSIFICATION	T3/TB2/F9/L2/D2

AIRFLOW	Pa ext	SFPv	Speed dim. used/Max, supply air	Speed dim. used/Max, extract air	POWER CONSUMPTION	Dry temperature efficiency	Conditions
m³/h	l/s	kW/m³/s	%	%	kW	%	
600	167	2,3	55	55	0,4	91%	
1900	528	1,2	56	55	0,6	87%	
3300	917	1,2	68	66	1,1	83%	
4600	1279	1,4	80	78	1,8	82%	
5900	1640	1,8	94	91	2,9	81%	

1. Calculated values at 200 Pa ext. pressure (150/50 Pa)
2. All data applies to fans with composite fan impeller
3. SFP and absorbed power calculated with clean filter
4. Speed dim. calculated at dim. filter pressure drop

DIMENSIONS (mm)

GLOBAL PX 24

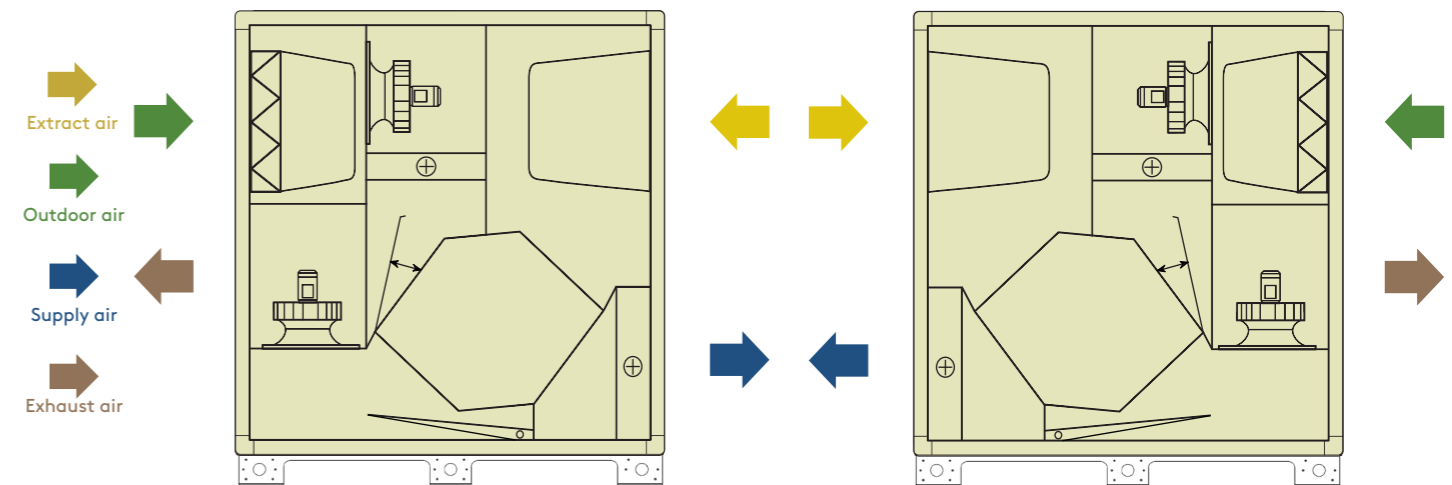
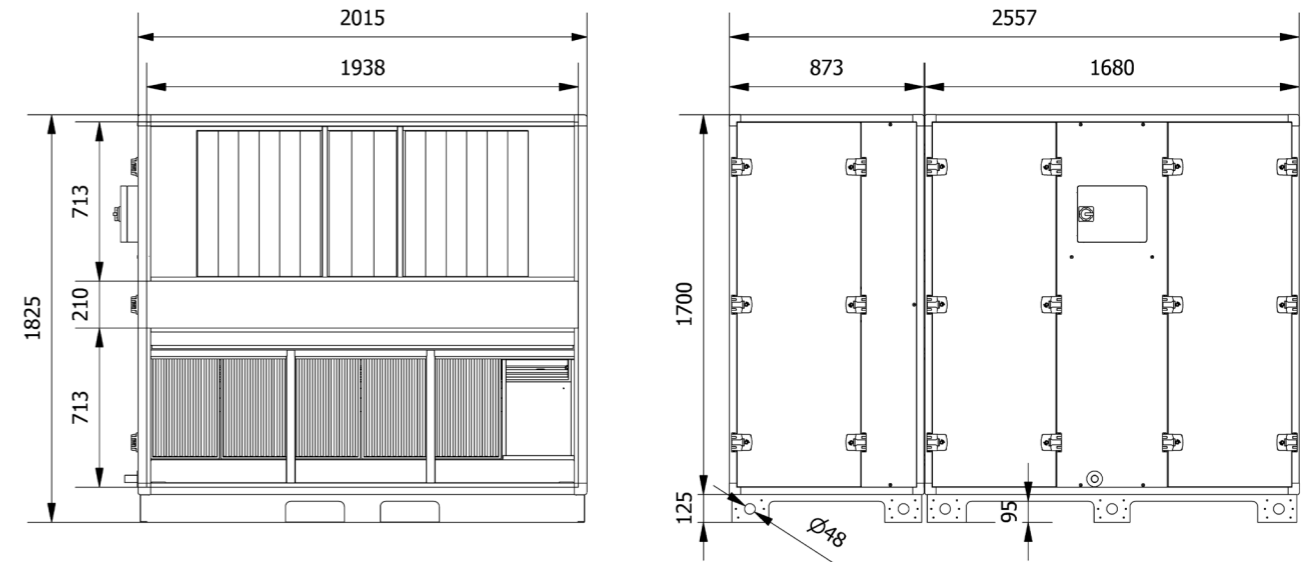

Right connection version

Left connection version

GLOBAL PX 26

FAN DIAGRAMS

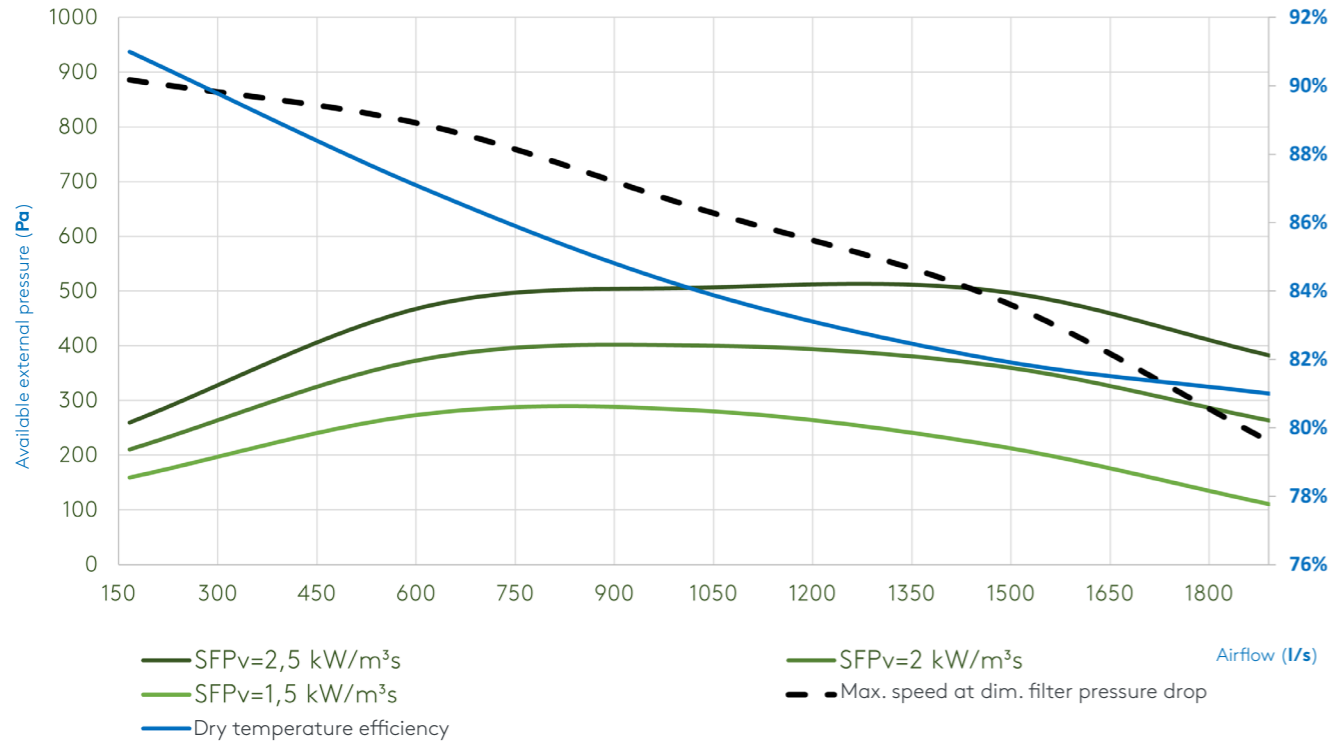

• AIRFLOW	600–6800 m³/h
	167–1890 l/s
• DIMENSIONS (L x W x H)	1825 x 2557 x 2396
• WEIGHT	1260 kg
• ELECTRIC POWER SUPPLY	3 x 400 V + N
• MAX. POWER CONSUMPTION	6.5 A
• RECOMMENDED FUSE PROTECTION	D10A - 10kA - AC3
• FILTER CLASS (BAG FILTER)	F7 (ePM1 70%) / M5 (ePM10 55%)
• CIRCULAR DUCT CONNECTIONS	NOT APPLICABLE
• STANDARD DUCT CONNECTIONS (15 mm)	2318 x 713
• GUIDE DUCT CONNECTIONS (20 mm) (W x H)	2300 x 700
• AMBIENT TEMPERATURE	-20°C ... +50°C
• EN1886 CLASSIFICATION	T3/TB2/F9/L2/D2

AIRFLOW	Pa ext	SFPv	Speed dim. used/Max, supply air	Speed dim. used/Max, extract air	POWER CONSUMPTION	Dry temperature efficiency	Conditions
m³/h	l/s	kW/m³/s	%	%	kW	%	
600	167	200	49	48	0,3	91%	
2200	612	200	58	56	0,7	87%	
3700	1029	200	69	67	1,2	84%	
5300	1473	200	85	82	2,1	82%	
6800	1890	200	99	97	3,4	81%	

1. Calculated values at 200 Pa ext. pressure (150/50 Pa)
2. All data applies to fans with composite fan impeller
3. SFP and absorbed power calculated with clean filter
4. Speed dim. calculated at dim. filter pressure drop

DIMENSIONS (mm)

GLOBAL PX 26

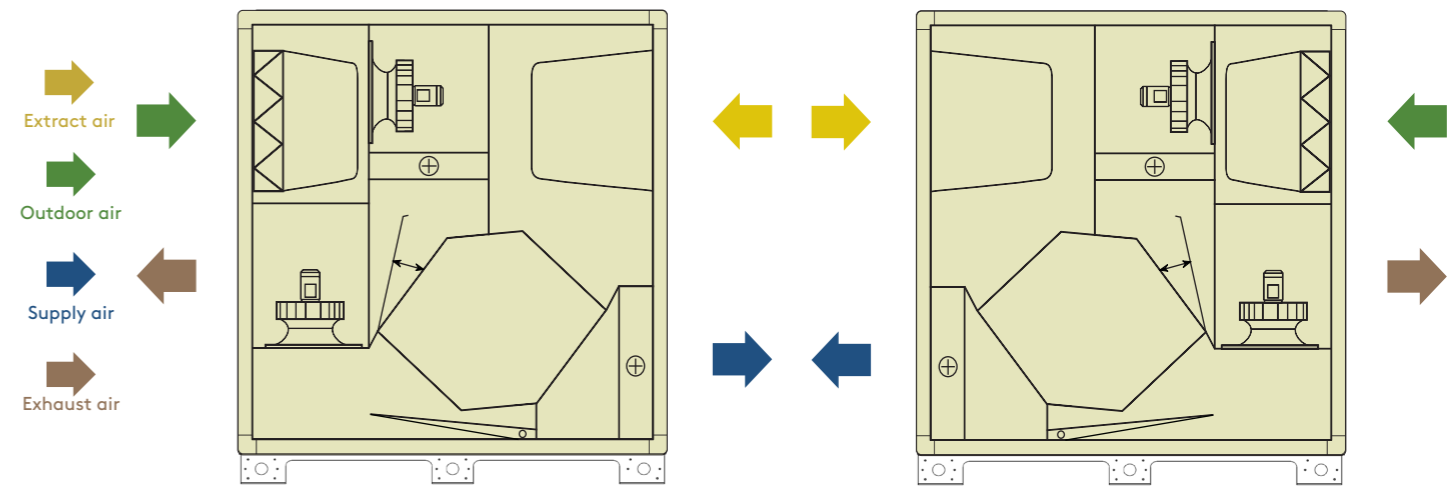
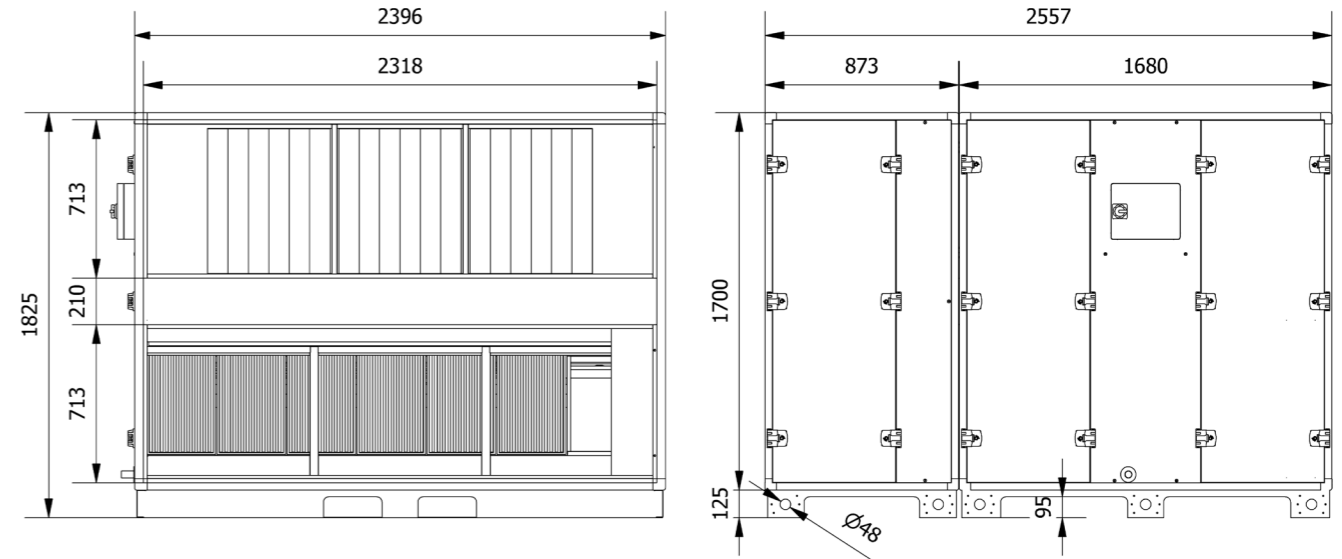

Right connection version

Left connection version

GLOBAL PX



Designation key:

Heat exchanger: Plate heat exchanger (PX)

Unit size: 04, 05, 06, 08, 12, 13, 16, 18, 20, 24, 26

Duct connection:

Supply air: right (R) / left (L)

Fan type: none = composite, ALU = aluminium

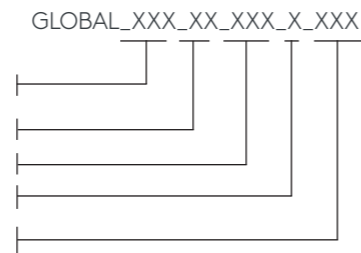

FLEXIBLE CONNECTION 20 MM



The flexible duct connections, type MS20, prevent vibrations from being propagated through the duct system. The connections are made of glass fibre-reinforced plastic and have fire resistance class M0 and air tightness class B (according to EN 15727 and EN 1751). They can handle operating temperatures from -30 to +110°C and pressure up to 2000 Pa. The 20 mm wide sleeve connection is made of 1 mm thick, galvanised sheet steel.

Designation key:

Connection frame width (mm)

Duct dimensions (mm)

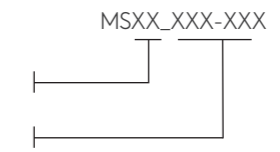

MODEL	DUCT DIMENSIONS [MM]	EXTERNAL DIMENSIONS [MM]	MARKING
GLOBAL PX 04/05	DN315	/	MS_315
GLOBAL PX 06/08	DN400	/	MS_400
GLOBAL PX 12/13	1060 x 540	1100 x 580	MS20_1060-540
GLOBAL PX 16	1520 x 540	1560 x 580	MS20_1520-540
GLOBAL PX 18	1895 x 540	1935 x 580	MS20_1895-540
GLOBAL PX 20	1520 x 670	1560 x 710	MS20_1520-670
GLOBAL PX 24	1895 x 670	1935 x 710	MS20_1895-670
GLOBAL PX 26	2275 x 670	2315 x 710	MS20_2275-670

SLIP-CLAMP CONNECTIONS 20 MM



Slip-clamp connections mean that the duct is connected to the unit with a standard guide and guide rail. The connection frame is made of 1 mm thick, galvanised sheet steel. Slip-clamp connections can only be supplied with fixed dimensions with a 100 mm interval, see the table below.

Designation key:

Connection frame width (mm)

Duct dimensions (mm)

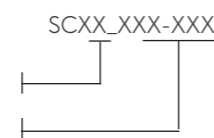

MODEL	DUCT DIMENSIONS [MM]	MARKING
GLOBAL PX 12/13	1100 x 600	SC20_1100-600
GLOBAL PX 16	1600 x 600	SC20_1600-600
GLOBAL PX 18	2000 x 600	SC20_2000-600
GLOBAL PX 20	1600 x 700	SC20_1600-700
GLOBAL PX 24	2000 x 700	SC20_2000-700
GLOBAL PX 26	2300 x 700	SC20_2300-700

FLEXIBLE CONNECTION 30 MM

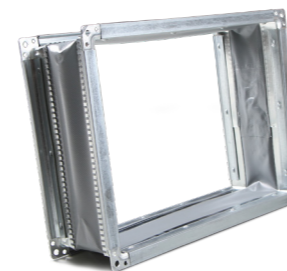

The flexible connections, type MS30, prevent vibrations from being propagated through the duct system. The connections are made of glass fibre-reinforced plastic and have fire resistance class M0 and air tightness class B (according to EN 15727 and EN 1751). They can handle operating temperatures from -30 to +110°C and pressure up to 2000 Pa. The 30 mm wide "METU" sleeve connection is made of 1 mm thick, galvanised sheet steel.

Designation key:

Connection frame width (mm)

Duct dimensions (mm)

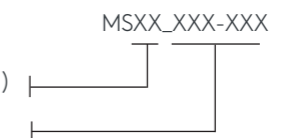

MODEL	DUCT DIMENSIONS [MM]	EXTERNAL DIMENSIONS [MM]	MARKING
GLOBAL PX 12/13	1040 x 520	1100 x 580	MS30_1040-520
GLOBAL PX 16	1500 x 520	1560 x 580	MS30_1500-520
GLOBAL PX 18	1875 x 520	1935 x 580	MS30_1875-520
GLOBAL PX 20	1500-650	1560 x 710	MS30_1500-650
GLOBAL PX 24	1875 x 650	1935 x 710	MS30_1875-650
GLOBAL PX 26	2255 x 650	2315 x 710	MS30_2255-650

REPLACEMENT FILTER SETS



The function of the filter is to keep both the air and the heat exchanger free from contaminants. Outdoor air filter class: ePM1 ≥ 70% Extract air filter class: ePM10 ≥ 55%. All filters are classified in accordance with both ISO EN 779 and ISO EN 16890. In order to keep the heat exchanger clean, filters of class ePM10 ≥ 55% are sufficient. In order to avoid impaired energy efficiency in the air handling unit, extract air filter sets of class ePM1 ≥ 70% are not supplied.

MODEL	DIMENSIONS, SUPPLY AIR FILTER [MM]	DIMENSIONS, EXTRACT AIR FILTER [MM]	NUMBER OF BAGS
GLOBAL PX 04/05/06/08	490 x 517 x 380	490 x 517 x 360	8 / 5
GLOBAL PX 12/13	892 x 592 x 360	892 x 592 x 360	12 / 9
GLOBAL PX 16	592 x 592 x 380 (x2)	592 x 592 x 360 (x2)	8 (x2) / 6 (x2)
GLOBAL PX 18	892 x 592 x 380 (x2)	892 x 592 x 360 (x2)	12 (x2) / 9 (x2)
GLOBAL PX 20	592 x 692 x 380 (x2)	592 x 692 x 360 (x2)	10 (x2) / 6 (x2)
GLOBAL PX 24	592 x 692 x 380 (x2) 340 x 692 x 380 (x1)	592 x 692 x 380 (x2) 340 x 692 x 380 (x1)	10 (x2) / 4 x 1 6 (x2) / 3 (x1)
GLOBAL PX 26	592 x 692 x 380 (x3)	592 x 692 x 360 (x3)	10 (x3) / 6 (x3)

PRE-FILTER CLASS G4



The pre-filter is installed in the outdoor air section, upstream of the fine filter. A pre-filter is used when the outdoor air is heavily contaminated, in order to prevent the fine filter from clogging up unreasonably quickly. The pre-filter has filter class G4 according to EN-779.

MODEL	DIMENSIONS [MM]
GLOBAL PX 04/05/06/08	490 x 517 x 50
GLOBAL PX 12/13	892 x 592 x 50
GLOBAL PX 16	592 x 592 x 50 (x2)
GLOBAL PX 18	892 x 592 x 50 (x2)
GLOBAL PX 20	592 x 692 x 380 (x2)
GLOBAL PX 24	592 x 692 x 380 (x2) 340 x 692 x 380 (x1)
GLOBAL PX 26	592 x 692 x 380 (x3)

BUILT-IN WATER POST HEATING COIL

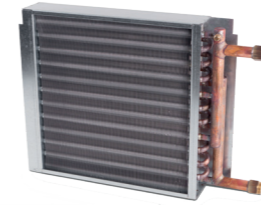

In the post-heater, hot water is used to reheat the supply air. The heater is integrated in the air handling unit, downstream of the heat exchanger. The heat exchanger is a tube heat exchanger, made of copper pipes supplied with surface-enlarging aluminium fins with a spacing of 2.5 mm. The pipes have external threaded pipe connections are made of brass. The heat exchanger is equipped with a venting plug. The pressure class is PN16.

Designation key:

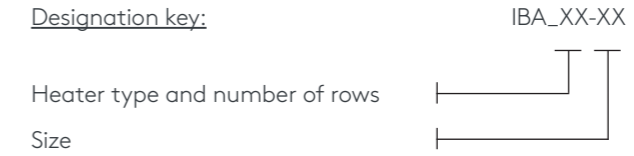

MODEL	Ø	MARKING
GLOBAL PX 04/05	1/2"	IBA_2H_PX 05
GLOBAL PX 06/08	1/2"	IBA_2H_PX 06/08
GLOBAL PX 12	1/2"	IBA_2H_PX 13
GLOBAL PX 16	1/2"	IBA_2H_PX 16
GLOBAL PX 18	1/2"	IBA_2H_PX 18
GLOBAL PX 20	3/4"	IBA_2H_PX20
GLOBAL PX 24	3/4"	IBA_2H_PX24
GLOBAL PX 26	3/4"	IBA_2H_PX26

BUILT-IN ELECTRIC PRE- AND POST-HEATERS



The electric heater is used to reheat the supply air and the pre-heater is used to prevent water from freezing in the counterflow heat exchanger. They are equipped with two overheating protection units, one with manual resetting (110°C) and the other with automatic resetting (75°C). All electrical connections are protected to prevent people from touching them.

Designation key:

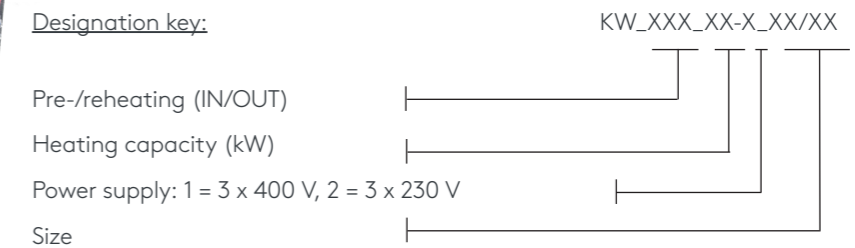

MODEL	POWER KW _{out}	POWER KW _{in}
GLOBAL PX 04/05	3.0 kW	3.0 kW
GLOBAL PX 06/08	6.0 kW	6.0 kW
GLOBAL PX 12/13	9.0 kW	9.0 kW
GLOBAL PX 16	12.0 kW	12.0 kW
GLOBAL PX 18	15.0 kW	15.0 kW
GLOBAL PX 20	15.0 kW	15.0 kW
GLOBAL PX 24	22.5 kW	22.5 kW
GLOBAL PX 26	22.5 kW	22.5 kW

INSULATED INTEGRATED CASING FOR EXTERNAL HEATERS/COOLERS



The insulated integrated casing has a sandwich construction, made of galvanised sheet steel, with 50 mm thick mineral wool insulation between the outer and the inner sheet steel. The outer sheet steel is painted in colour RAL7016. The casings can be used for the integration of external heaters, coolers and direct expansion units (EBA), and can be installed directly on the unit or in the duct system. The standard sleeve connection is 15 mm. Other connection types are available as options: 20 mm guide rails, 30 mm "METU" connections. The unit is fitted with a 125 mm base frame.

Designation key:

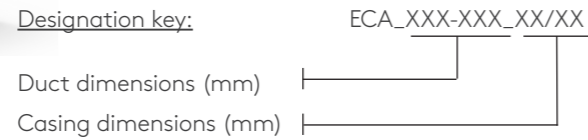

MODEL	DUCT CONNECTION [MM]	DUCT CONNECTION	DIMENSIONS [MM]	MARKING
GLOBAL PX 04/05	530 x 505	DN315	670 x 697 x 815	ECA_530-505
GLOBAL PX 06/08	735 x 505	DN400	670 x 697 x 815	ECA_735-505
GLOBAL PX12/13	1105 x 580	/	670 x 772 x 1182	ECA_1105-580
GLOBAL PX 16	1560 x 580	/	670 x 772 x 1640	ECA_1560-580
GLOBAL PX 18	1935 x 580	/	670 x 772 x 2015	ECA_1935-580
GLOBAL PX 20	1560 x 710	/	670 x 902 x 1640	ECA_1560-710
GLOBAL PX 24	1935 x 710	/	670 x 902 x 2015	ECA_1935-710
GLOBAL PX 26	2315 x 710	/	670 x 902 x 2395	ECA_2315-710

CIRCULAR/RECTANGULAR ADAPTER



Uninsulated adapters for the transition between circular and rectangular connections are available for units and post-treatment sections with rectangular connections. The adapters are made of galvanised sheet steel. The circular duct connection is fitted with a rubber seal.

Designation key:

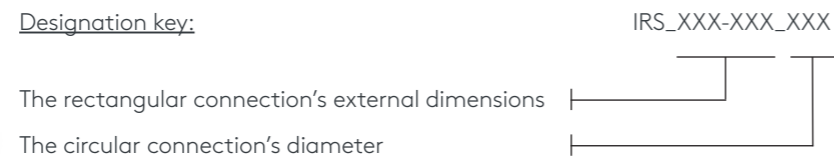

MODEL	DIMENSIONS [MM]	MARKING
GLOBAL PX 12/13	1140 x 615 - DN500	IRS_1140-615_500

HEAT EXCHANGER FOR INTEGRATION IN INSULATED CASING

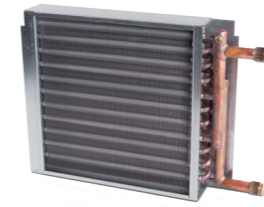

In the EBA heat exchanger, water or refrigerant is used to post-treat the supply air. The heat exchanger is designed for integration in insulated casing ECA. The heat exchanger is a tube heat exchanger, made of copper pipes and aluminum fins with a spacing of 2.5 mm. The pipes have external threaded pipe connections are made of brass. The heat exchanger is supplied with a venting plug (not for DX). The pressure class is PN16.

Designation key:

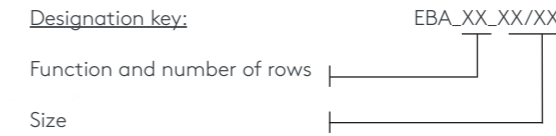

MODEL	FUNCTION	NUMBER OF CIRCUITS	VOLUME	DIMENSIONS [MM]	Ø	MARKING
GLOBAL PX 04/05	HEATING	3	1.7 dm ³	440 x 500 x 130	1/2"	EBA_4H_PX 05
GLOBAL PX 04/05	COOLING	3	1.7 dm ³	440 x 500 x 130	1/2"	EBA_4C_PX 05
GLOBAL PX 04/05	DX	3	2.1 dm ³	440 x 500 x 130	Ø22/Ø16	EBA_4X_PX 05
GLOBAL PX 06/08	HEATING	3	2.4 dm ³	440 x 705 x 130	1/2"	EBA_4H_RX 08 - PX 06/08
GLOBAL PX 06/08	COOLING	3	2.4 dm ³	440 x 705 x 130	1/2"	EBA_4C_RX 08 - PX 06/08
GLOBAL PX 06/08	DX	4	2.9 dm ³	440 x 705 x 130	Ø22/Ø16	EBA_4X_RX 08 - PX 06/08
GLOBAL PX 12/13	HEATING	4	4.5 dm ³	515 x 885 x 130	1/2"	EBA_4H_PX 12/13
GLOBAL PX 12/13	COOLING	4	4.5 dm ³	515 x 885 x 138	1/2"	EBA_4C_PX 12/13
GLOBAL PX 12/13	DX	4	4.5 dm ³	515 x 885 x 130	Ø28/Ø22	EBA_4X_PX 12/13
GLOBAL PX 16	HEATING	4	6.5 dm ³	515 x 1530 x 130	3/4"	EBA_4H_PX 16
GLOBAL PX 16	COOLING	4	6.5 dm ³	515 x 1430 x 130	3/4"	EBA_4C_PX 16
GLOBAL PX 16	DX	4	7.6 dm ³	515 x 1430 x 130	Ø28/Ø22	EBA_4X_PX 16
GLOBAL PX 18	HEATING	4	6.2	515 x 1430 x 130	Ø3/4"	EBA_4H_PX 18
GLOBAL PX 18	COOLING	4	6.2	515 x 1430 x 130	Ø3/4"	EBA_4C_PX 18
GLOBAL PX 18	DX	3	5.4	515 x 1430 x 130	Ø28/Ø22	EBA_4X_PX 18
GLOBAL PX 20	HEATING	4	8.6 dm ³	645 x 1272 x 130	3/4"	EBA_4H_PX 20
GLOBAL PX 20	COOLING	4	8.6 dm ³	645 x 1272 x 130	3/4"	EBA_4C_PX 20
GLOBAL PX 20	DX	4	8.2 dm ³	645 x 1272 x 130	Ø26/Ø22	EBA_4X_PX 20
GLOBAL PX 24	HEATING	4	10.5 dm ³	645 x 1530 x 130	1"	EBA_4H_PX 24
GLOBAL PX 24	COOLING	4	10.5 dm ³	645 x 1530 x 130	1"	EBA_4C_PX 24
GLOBAL PX 24	DX	4	9.0 dm ³	645 x 1530 x 130	Ø35/Ø28	EBA_4X_PX 24
GLOBAL PX 26	HEATING	4	10.5 dm ³	645 x 1530 x 130	1"	EBA_4H_PX 26
GLOBAL PX 26	COOLING	4	10.5 dm ³	645 x 1530 x 130	1"	EBA_4C_PX 26
GLOBAL PX 26	DX	4	9.0 dm ³	645 x 1530 x 130	Ø35/Ø28	EBA_4X_PX 26

MOTOR-DRIVEN DAMPERS



The CT dampers are used as shut-off dampers. Shut-off dampers are used if the air handling unit is not going to be used for a period of time, or if a water heating coil or cooler is used. Rectangular shut-off dampers are factory installed and wired, circular ones are supplied separately. The damper frame is made of galvanised steel, the damper blade in rectangular dampers is made of extruded aluminium. The damper blades have rubber seals. Air-tightness according to EN 1751 is class 3 for circular dampers and class 2 for rectangular dampers.

Designation key:

Connection frame (mm)

Duct dimensions (mm)

Without actuator = 0

On/off = SM01

Spring return = SM02

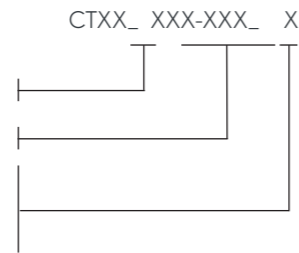

MODEL	DUCT DIMENSIONS [MM]	EXTERNAL DIMENSIONS [MM]	MARKING
GLOBAL PX 04/05	DN315	DN315	CT_315
GLOBAL PX 06/08	DN400	DN400	CT_400
GLOBAL PX 12/13	1020 x 500	1100 x 580	CT40_1020-500
GLOBAL PX 16	1480 x 500	1560 x 580	CT40_1480-500
GLOBAL PX 18	1855 x 500	1935 x 580	CT40_1855-500
GLOBAL PX 20	1480 x 630	1560 x 710	CT40_1480-630
GLOBAL PX 24	1855 x 630	1935 x 710	CT40_1855-630
GLOBAL PX 26	2235 x 630	2315 x 710	CT40_2235-630

ROOF FOR OUTDOOR INSTALLATION



The roof for outdoor installation is supplied as a complete kit for assembling the unit at the installation site.

Designation key:

Size of the roof [mm]

OUT_XXX-XXX

MODEL	DIMENSIONS [MM]	MARKING
GLOBAL PX 04/05	1670 x 750	OUT_1820-750
GLOBAL PX 06/08	1820 x 955	OUT_1820-955
GLOBAL PX 12/13	1820 x 1320	OUT_1820-1320
GLOBAL PX 16	1820 x 1780	OUT_1820-1780
GLOBAL PX 18	2020 x 2155	OUT_2020-2155
GLOBAL PX 20	810 x 2155	OUT_810-2155
GLOBAL PX 24	2690 x 1780	OUT_2690-1780
GLOBAL PX 24	2690 x 2155	OUT_2690-2155
GLOBAL PX 26	2690 x 2535	OUT_2690-2535

INTAKE HOOD WITH PROTECTIVE GRILLE

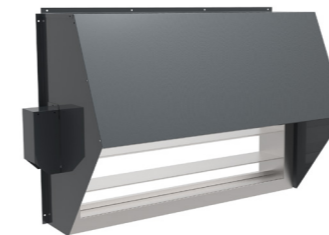

The intake section is screwed onto the air handling unit's duct connection. The accessory is supplied from the factory, fully assembled with complete electrical connections.

Designation key:

The intake hood's connection dimensions

AUi_XX/XX

MODEL	MARKING	MARKING	DIMENSIONS [MM]
GLOBAL PX 04/05	AUi_315	AUCTi_315	340 x 600
GLOBAL PX 06/08	AUi_400	AUCTi_400	440 x 600
GLOBAL PX 12/13	AUi_1110-585	AUCTi_1110-585	1110 x 585
GLOBAL PX 16	AUi_1565-585	AUCTi_1565-585	1565 x 585
GLOBAL PX 18	AUi_1940-585	AUCTi_1940-585	1940 x 585
GLOBAL PX 20	AUi_1565-715	AUCTi_1565-715	1565 x 715
GLOBAL PX 24	AUi_1940-715	AUCTi_1940-715	1940 x 715
GLOBAL PX 26	AUi_2320-715	AUCTi_2320-715	2320-715

EXHAUST AIR HOOD WITH PROTECTIVE GRILLE

The exhaust air section is screwed onto the air handling unit's duct connection. The accessory is supplied from the factory, full assembled with complete electrical connections.



Designation key:

AUe_XX/XX

The intake hood's connection dimensions |

MODEL	MARKING	MARKING	DIMENSIONS [MM]
GLOBAL PX 04/05	AUe_315	AUCTe_315	340 x 600
GLOBAL PX 06/08	AUe_400	AUCTe_400	440 x 600
GLOBAL PX 12/13	AUi_1110-585	AUCTe_1110-585	1110 x 585
GLOBAL PX 16	AUi_1565-585	AUCTe_1565-585	1565 x 585
GLOBAL PX 18	AUe_1940-585	AUCTe_1940-585	1940 x 585
GLOBAL PX 20	AUi_1565-715	AUCTe_1565-715	1565 x 715
GLOBAL PX 24	AUi_1940-715	AUCTe_1940-715	1940 x 715
GLOBAL PX 26	AUi_2320-715	AUCTe_2320-715	2320-715

Feel good **inside**



Swegon 